



Contents

1.0 Gate Valves	5
2.0 Butterfly Valves	30
3.0 Check Valves	48
4.0 Globe Valves	71
5.0 Balancing Valves	77
6.0 Y-Pattern Strainer Valves	83
7.0 Quarter Turn Ball Valves	91
8.0 Air Release Valves	119
9.0 Automatic Control Valves	123
10.0 Rubber Flexible Connectors	129
11.0 Pressure Independent Control Valves	135
12.0 Plunger Valves	145
13.0 Product Guarantee	148
14.0 Notes	149

For specific applications, users are advised to contact Conex Universal Ltd for technical advice, or to complete their own evaluation to prove technical suitability of the products. Failure to follow this may result in damage and personal injury for which Conex Universal Ltd cannot be held liable.

110 years of innovation

Conex Bänninger specialises in providing fittings, valves and accessories across the globe by offering innovative and versatile solutions. Since 1909, Conex Bänninger has produced over 22 billion fittings and valves and has built its reputation for quality European manufacturing, backed by first-class customer service and unrivalled expertise.

Passionate about excellence, Conex Bänninger is a by word for quality in the domestic, commercial, industrial, shipbuilding, air conditioning and refrigeration markets worldwide. Conex Bänninger is an ISO 9001 quality assured company, which assures you the very best in quality.





1.0 Gate Valves

Conex Bänninger Gate Valves are used for permitting or preventing flow and are best used in systems that require infrequent use of the valve. When fully open, full flow occurs, giving minimal resistance or pressure drop.

- Conex Bänninger Gate Valves are designed with a full bore in order to minimise flow resistance and pressure drop. In order to prevent water hammer and therefore damage to the valve or pipework, the gate is designed to open relatively slowly. Prolonged inactivity will not result in difficulty of operation. This makes them the preferred choice for isolation applications where pressure surges (hydraulic shock) should be avoided and where the valve is used infrequently.
- Gate valves are designed to be used in the fully open or closed position, and should not be used for throttling the flow. Where throttling is required, we recommend Conex Bänninger Globe Valves.
- By nature of design, gate valves are not capable of accurate flow regulation; therefore globe valves should be used for this level of control.
- Conex Bänninger Gate Valves are available in both rising and non-rising stem.
- This comprehensive range of gate valves is manufactured from ductile iron as well as high quality brass, DZR brass and bronze (red brass), which has excellent resistance to corrosion.

Features and benefits include:

- DN15 – DN600.
- Valve variants may be operated by handwheel, T key or electric actuator.
- Valves have been designed to comply with applicable standards.
- End connections, threaded and flanged.
- Variants manufactured from brass, DZR brass, bronze and ductile iron.
- Ductile iron valves are electrostatically coated with corrosion resistant epoxy powder internally and externally.
- Variants WRAS approved for potable water service.
- Valve variants with non-rising stem for installations where space is limited.
- Valve variants with stem cap for buried applications.
- Ductile iron valves designed with three O-ring stem seals for zero leakage.



1120 Gate Valve Handwheel PN20 - light pattern - (brass)

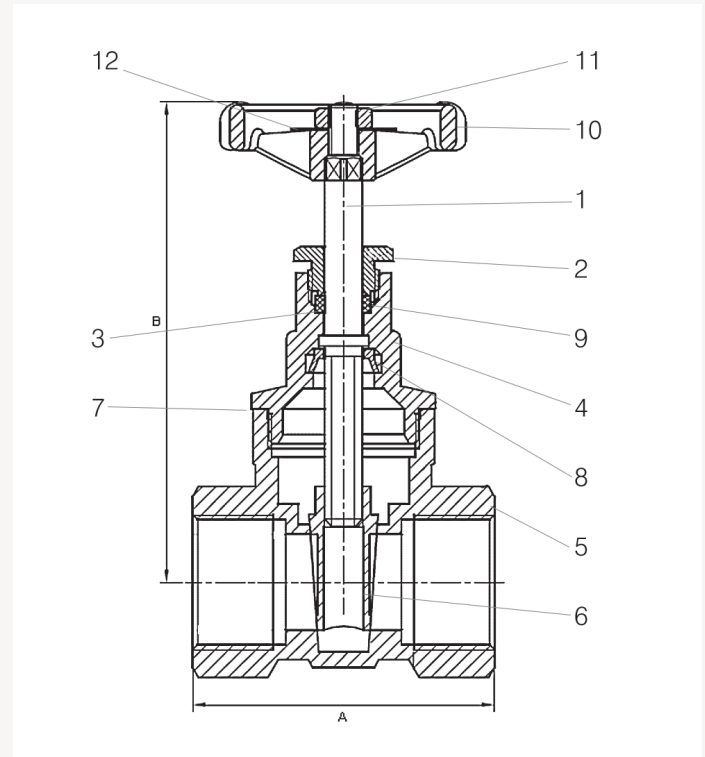

Material specification

1120 Handwheel version 1/2" to 2"

No	Component	Material	Specification
1	Stem	Brass	EN 12164 CW617N-DW
2	Packing nut	Brass	EN 12164 CW614N
3	Packing	PTFE	PTFE
4	Bonnet	Brass	EN 12165 CW617N-DW
5	Body	Brass	EN 12165 CW617N-DW
6	Wedge	Brass	EN 12165 CW617N-DW
7	Seal	PTFE	PTFE
8	Stem retainer	DZR brass	EN 12164 CW602N
9	Packing ring	Brass	EN 12164 CW614N
10	Handwheel	Aluminium	EN 1706 LM6
11	Handwheel nut	Brass	EN 12164 CW614N
12	Identity disc	Aluminium	EN 1706 LM6

Gate valves are designed for services that only need infrequent operation, where the gate is maintained at either fully open or fully closed. They should not be used for throttling the flow of fluid.

Features and benefits:

- Non-rising stem.
- Designed in accordance with EN 12288 requirements.
- High quality brass construction.
- End connections, female taper threads to EN 10226-2 (ISO 7-1) and parallel threads to ISO 228.
- WRAS approved for drinking water.
- Suitable for low temperature hot water systems.
- Not suitable for high temperature working, temperatures above 100 °C.
- Unique Conex Bänninger handwheel.

1120 Gate Valve

Order code EN 10226 (ISO 7-1) thread	Order code ISO 228 thread	Size	DN	A	B	Kv value	Weight (kg)
112010RRW200404	112014FFW200404	1/2"	15	48	70	17	0.25
112010RRW200606	112014FFW200606	3/4"	20	50	80	32	0.39
112010RRW200808	112014FFW200808	1"	25	60	90	52	0.58
112010RRW201010	112014FFW201010	1.1/4"	32	64	115	102	0.98
112010RRW201212	112014FFW201212	1.1/2"	40	69	125	170	1.10
112010RRW201616	112014FFW201616	2"	50	81	155	224	1.80

Valve suitability

Product	Steam	Water	Drinking water	Oil	Air (oil free)	Gas (inert)	Gas (combustible)	Gas (corrosive)	Gas (oxygen)
1120	x	✓	✓	✓	x	x	x	x	x

Max. working parameters

1120	Temperature °C	Pressure bar	Pressure psi
Water	-10 to +100	20	290

Specification clauses:

- Designed in accordance with EN 12288 requirements.
- Non-rising stem.
- Handwheel operated.
- Brass threaded bonnet and one piece wedge.
- End connections, female taper threads to EN 10226-2 (ISO 7-1) and parallel threads to ISO 228.
- WRAS approved for drinking water systems.
- Suitable for low temperature hot water systems.

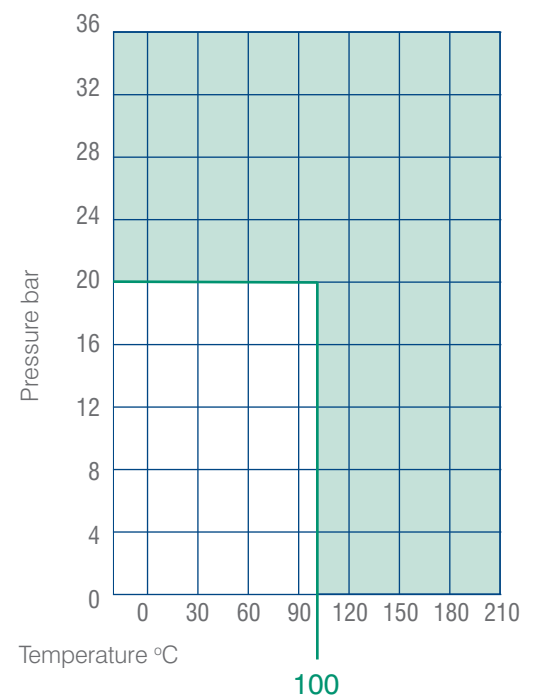

2121 Gate Valve Handwheel PN20 (bronze)

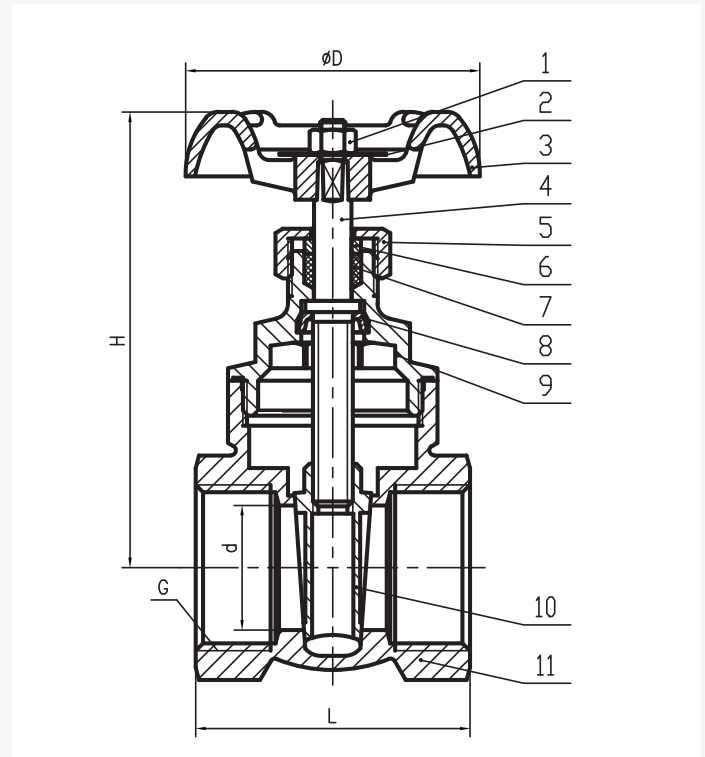

Material specification

2121 Handwheel Version 1/2" to 4"

No	Component	Material
1	Nut	Brass CW614N
2	ID plate	Aluminium
3	Handwheel*	Aluminium
3	Handwheel**	Cast iron
4	Stem	Brass CW602N
5	Packing nut	Brass CW614N
6	Ring***	Brass CW617N
7	Packing	PTFE
8	Stem bush	Brass CW602N
9	Bonnet	Bronze CC491K
10	Disc	Bronze CC491K
11	Body	Bronze CC491K

* 1/2" to 2 1/2" only, ** 3" to 4" only, *** 1 1/2" to 4" only

Gate valves are designed for services that only need infrequent operation, where the gate is maintained at either fully open or fully closed. They should not be used for throttling the flow of fluid.

Features and benefits:

- WRAS approved for drinking water systems.
- Pressure rating: PN20.
- Working medium: water and oil.
- Working temperature: -10 °C to 170 °C.
- Designed in accordance to EN 12288 requirements.
- High quality bronze construction immune to dezincification and stress corrosion cracking resistant.
- Robust construction ensures reliable in-process service.
- Bronze material in accordance with EN 1982.
- End connections, ISO 7-1 female taper BSPT threads.
- Suitable for use with low temperature hot water and chilled systems.

2121 Gate Valve Handwheel PN20 (bronze) 1/2" to 4"

Order code	Size	DN	d	L	H	D
212120RRW200404	1/2"	15	13	43	78	52
212120RRW200606	3/4"	20	19	49	92	60
212120RRW200808	1"	25	25	54	103	60
212120RRW201010	1 1/4"	32	32	62	116	70
212120RRW201212	1 1/2"	40	38	65	133	78
212120RRW201616	2"	50	50	75	158	92
212120RRW202020	2 1/2"	65	63	87	190	100
212120RRW202424	3"	80	76	105	215	110
212120RRW203232	4"	100	100	124	258	130

Valve suitability

Product	Steam	Water	Drinking water	Oil	Air (oil free)	Gas (inert)	Gas (combustible)	Gas (corrosive)	Gas (oxygen)
2121	x	✓	✓	✓	x	x	x	x	x

Max. working parameters

2121	Temperature °C	Pressure bar	Pressure psi
Water	-10 to +170	20	290

Specification clauses:

- WRAS approved for drinking water systems.
- Bronze material in accordance with EN 1982.
- High quality bronze construction immune to dezincification and stress corrosion cracking resistant.
- Designed in accordance to EN 12288 requirements.
- Robust construction ensures reliable in-process service.
- Pressure rating: PN20.
- Working medium: water and oil.
- Working temperature: -10 °C to 170 °C.
- End connections, ISO 7-1 female taper BSPT threads.
- Suitable for use with low temperature hot water and chilled systems.

2121 Gate Valve Lockshield PN20 (bronze)

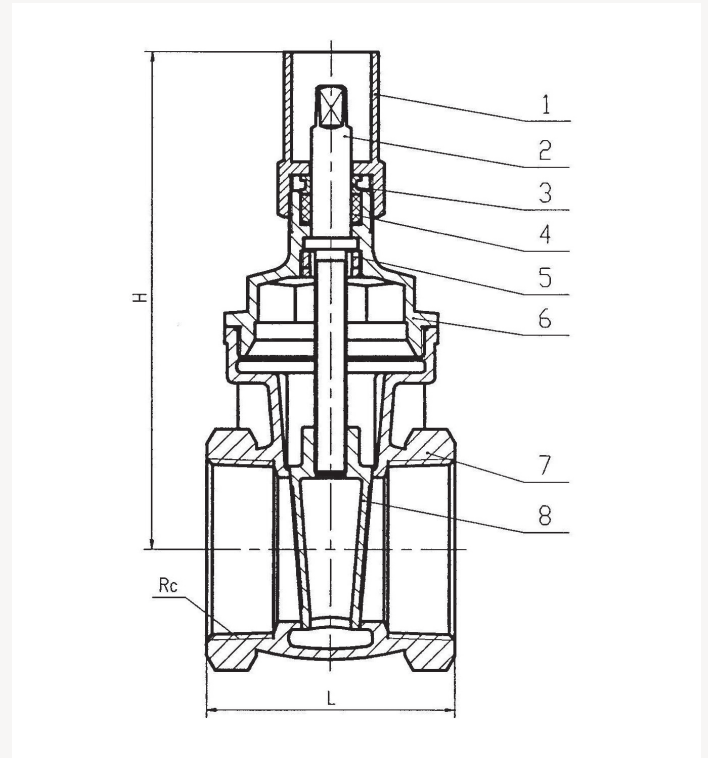

Material specification

2121 Lockshield version 1/2" to 4"

No	Component	Material
1	Stem	DZR brass CW602N
2	Lockshield	Brass CW614N
3	Clamping ring	Brass CW617N
4	Packing	PTFE
5	Stem bush	DZR brass CW602N
6	Bonnet	Bronze CC491K
7	Body	Bronze CC491K
8	Disc	Bronze CC491K

Gate valves are designed for services that only need infrequent operation, where the gate is maintained at either fully open or fully closed. They should not be used for throttling the flow of fluid.

Features and benefits:

- Pressure rating: PN20.
- Working medium: water and oil.
- Working temperature: -10 °C to 170 °C.
- Designed in accordance to EN 12288 requirements.
- High quality bronze construction immune to dezincification and stress corrosion cracking resistant.
- Robust construction ensures reliable in-process service.
- Lockshield key operated.
- Bronze material in accordance with EN 1982.
- End connections, ISO 7-1 female taper BSPT threads.
- Suitable for use with low temperature hot water and chilled systems.

2121 Gate Valve Lockshield PN20 (bronze) 1/2" to 2"

Order code	Size	DN	L	H
212120RRK200404	1/2"	15	43	78
212120RRK200606	3/4"	20	49	86
212120RRK200808	1"	25	54	105
212120RRK201010	1 1/4"	32	62	116
212120RRK201212	1 1/2"	40	65	133
212120RRK201616	2"	50	75	155

Valve suitability

Product	Steam	Water	Drinking water	Oil	Air (oil free)	Gas (inert)	Gas (combustible)	Gas (corrosive)	Gas (oxygen)
2121	x	✓	x	✓	x	x	x	x	x

Max. working parameters

2121	Temperature °C	Pressure bar	Pressure psi
Water	-10 to +100	20	290

Specification clauses:

- Bronze material in accordance with EN 1982.
- High quality bronze construction immune to dezincification and stress corrosion cracking resistant.
- Designed in accordance to EN 12288 requirements.
- Robust construction ensures reliable in-process service.
- Lockshield key operated.
- Pressure rating: PN20.
- Working medium: water and oil.
- Working temperature: -10 °C to 170 °C.
- End connections, ISO 7-1 female taper BSPT threads.
- Suitable for use with low temperature hot water and chilled systems.

1122 Gate Valve Handwheel PN20 - (brass)

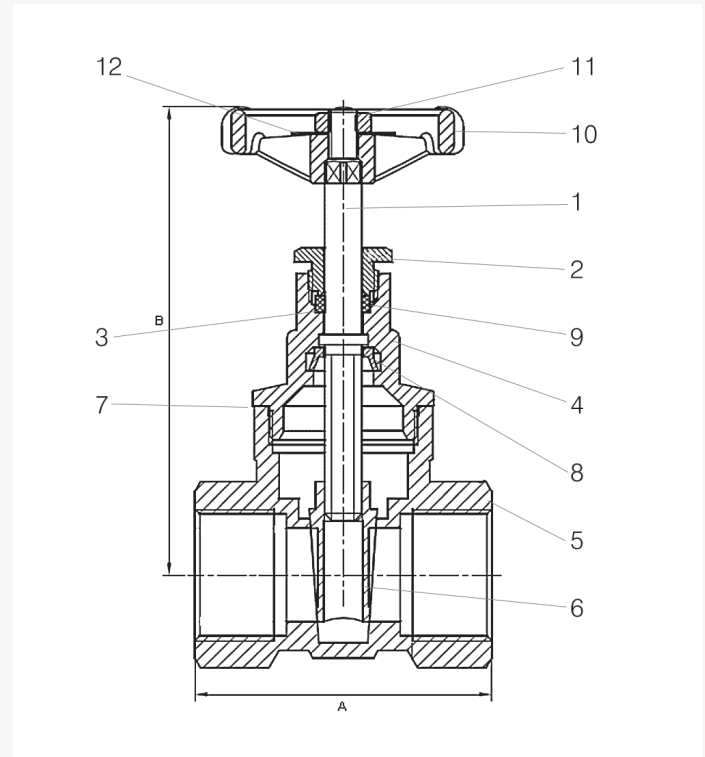

Material specification

1122 Handwheel version 1/2" to 4"

No	Component	Material	Specification
1	Stem	Brass	EN 12164 CW617N-DW
2	Packing nut	Brass	EN 12164 CW614N
3	Packing	PTFE	PTFE
4	Bonnet	Brass	EN 12165 CW617N-DW
5	Body	Brass	EN 12165 CW617N-DW
6	Wedge	Brass	EN 12165 CW617N-DW
7	Seal	PTFE	PTFE
8	Stem retainer	DZR brass	EN 12164 CW602N
9	Packing ring	Brass	EN 12164 CW614N
10	Handwheel	Aluminium	EN 1706 LM6
11	Handwheel nut	Brass	EN 12164 CW614N
12	Identity disc	Aluminium	EN 1706 LM6

Gate valves are designed for services that only need infrequent operation, where the gate is maintained at either fully open or fully closed. They should not be used for throttling the flow of fluid.

Features and benefits:

- High quality brass construction.
- Non-rising stem.
- End connections, female taper threads to EN 10226-2 (ISO 7-1) and parallel threads to ISO 228.
- WRAS approved for drinking water systems.
- Suitable for low temperature hot water systems.
- Unique Conex Bänninger handwheel.

1122 Gate Valve

Order code EN 10226-2 (ISO 7-1) thread	Order code ISO 228 thread	Size	DN	A	B	Kv value	Weight (kg)
112210RRW200404	112210FFW200404	1/2"	15	55	85	16	0.28
112210RRW200606	112210FFW200606	3/4"	20	60	95	32	0.40
112210RRW200808	112210FFW200808	1"	25	70	115	52	0.57
112210RRW201010	112210FFW201010	1.1/4"	32	75	125	100	0.96
112210RRW201212	112210FFW201212	1.1/2"	40	80	145	172	1.13
112210RRW201616	112210FFW201616	2"	50	90	165	230	1.9
112210RRW202020*	112210FFW202020*	2.1/2"	65	100	210	-	3.07
112210RRW202424*	112210FFW202424*	3"	80	115	240	-	4.40
112210RRW203232*	112210FFW203232*	4"	100	135	290	-	7.95

*Valves available to special order.

Valve suitability

Product	Steam	Water	Drinking water	Oil	Air (oil free)	Gas (inert)	Gas (combustible)	Gas (corrosive)	Gas (oxygen)
1122	x	✓	✓	✓	x	x	x	x	x

Max. working parameters

1122	Temperature °C	Pressure bar	Pressure psi
Water	-10 to +100	20	290

Specification clauses:

- Handwheel operated.
- Non-rising stem.
- Brass threaded bonnet and one piece wedge.
- End connections, female taper threads to EN 10226-2 (ISO 7-1) and parallel threads to ISO 228.
- WRAS approved for drinking water systems.
- Suitable for low temperature hot water systems.

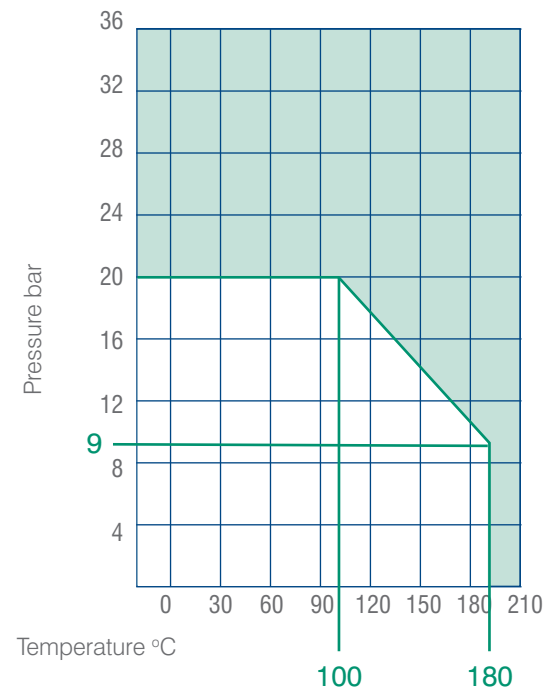

1122 Gate Valve Lockshield PN20 - (brass)

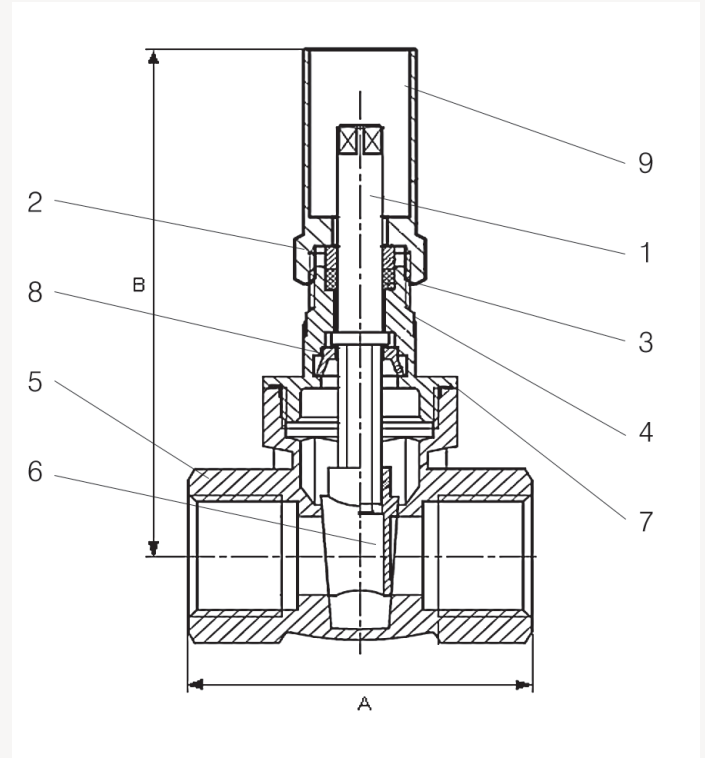

Material specification

1122 Lockshield version 1/2" to 4"

No	Component	Material	Specification
1	Stem	Brass	EN 12164 CW617N-DW
2	Packing nut	Brass	EN 12164 CW614N
3	Packing	PTFE	PTFE
4	Bonnet	Brass	EN 12165 CW617N-DW
5	Body	Brass	EN 12165 CW617N-DW
6	Wedge	Brass	EN 12165 CW617N-DW
7	Seal	PTFE	PTFE
8	Stem retainer	DZR brass	EN 12164 CW602N-DW
9	Lockshield	Brass	EN 12164 CW614N

Gate valves are designed for services that only need infrequent operation, where the gate is maintained at either fully open or fully closed. They should not be used for throttling the flow of fluid.

Features and benefits:

- Non-rising stem.
- Lockshield key operated.
- End connections, female taper threads designed to EN 10226-2 (ISO 7-1) and parallel threads to ISO 228.
- WRAS approved for drinking water systems.
- Suitable for low temperature hot water systems.

1122 Gate Valve

Order code EN 10226-2 (ISO 7-1) thread	Order code ISO 228 thread	Size	DN	A	B	Kv value	Weight (kg)
112210RRK200404	112210FFK200404	1/2"	15	55	85	16	0.26
112210RRK200606	112210FFK200606	3/4"	20	60	95	32	0.40
112210RRK200808	112210FFK200808	1"	25	65	110	52	0.57
112210RRK201010	112210FFK201010	1.1/4"	32	75	125	100	0.95
112210RRK201212	112210FFK201212	1.1/2"	40	80	145	172	1.12
112210RRK201616	112210FFK201616	2"	50	90	170	230	1.80
112210RRK202020*	112210FFK202020*	2.1/2"	65	100	210	-	2.83
112210RRK202424*	112210FFK202424*	3"	80	115	240	-	4.15
112210RRK203232*	112210FFK203232*	4"	100	135	290	-	7.43

*Valves available to special order.

A--GVLKKEY-- Lockshield key for valves 1/2" to 1"

B--GVLKKEY-- Lockshield key for valves 1.1/4" to 2"

Valve suitability

Product	Steam	Water	Drinking water	Oil	Air (oil free)	Gas (inert)	Gas (combustible)	Gas (corrosive)	Gas (oxygen)
1122	x	✓	✓	✓	x	x	x	x	x

Max. working parameters

1122	Temperature °C	Pressure bar	Pressure psi
Water	-10 to +100	20	290

Specification clauses:

- Non-rising stem.
- Lockshield key operated.
- Brass threaded bonnet and one piece wedge.
- End connections, female taper threads to EN 10226-2 (ISO 7-1) and parallel threads to ISO 228.
- WRAS approved for drinking water systems.
- Suitable for low temperature hot water systems.

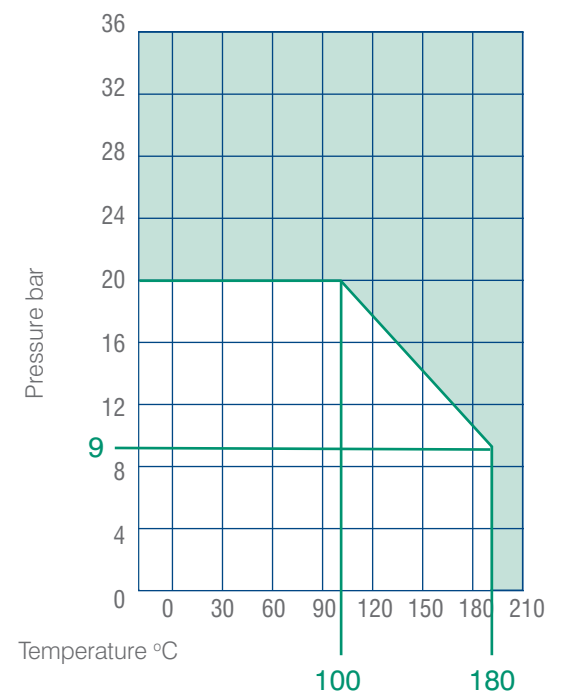

1124 Gate Valve Handwheel PN20 - (DZR)

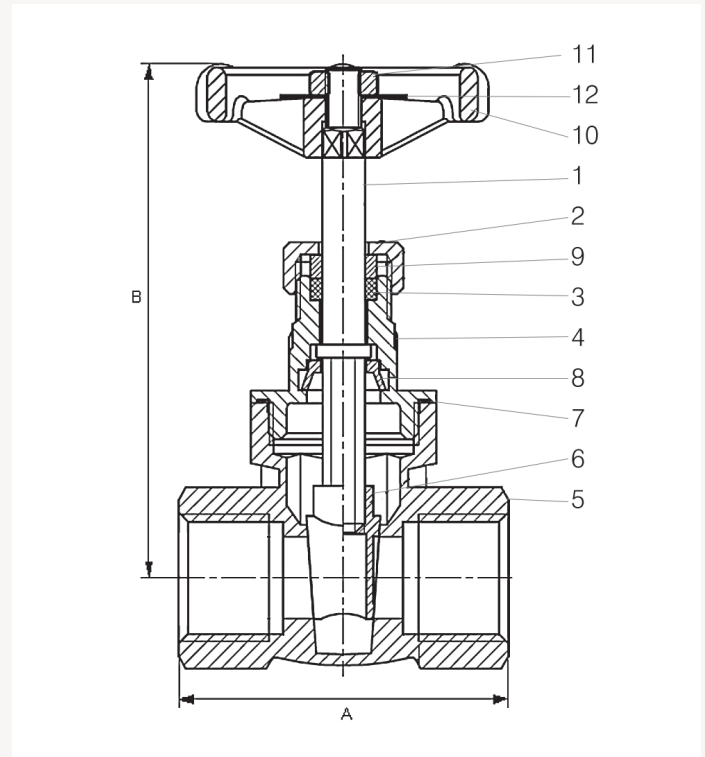

Material specification

1124 Handwheel version 1/2" to 4"

No	Component	Material	Specification
1	Stem	DZR brass	EN 12164 CW602N
2	Packing nut	Brass	EN 12164 CW614N
3	Packing	PTFE	PTFE
4	Bonnet	DZR brass	EN 12165CW602N
5	Body	DZR brass	EN 12165 CW602N
6	Wedge	DZR brass	EN 12165 CW602N
7	Seal	PTFE	PTFE
8	Stem retainer	DZR brass	EN 12164 CW602N
9	Packing ring	Brass	EN 12164 CW614N
10	Handwheel	Aluminium	EN 1706 LM6
11	Handwheel nut	Brass	EN 12164 CW614N
12	Identity disc	Aluminium	EN 1706 LM6

Gate valves are designed for services that only need infrequent operation, where the gate is maintained at either fully open or fully closed. They should not be used for throttling the flow of fluid.

Features and benefits:

- Dezincification resistant brass construction prevents system corrosion and limits fungal growth.
- End connections, female taper threads to EN 10226-2 (ISO 7-1) and parallel threads to ISO 228.
- WRAS approved for drinking water systems.
- Suitable for use with low temperature hot water and chilled systems.
- Unique Conex Bänninger handwheel.

1124 Gate Valve

Order code EN 10226-2 (ISO 7-1) thread	Order code ISO 228 thread	Size	DN	A	B	Kv value	Weight (kg)
112450RRW200404	112450FFW200404	1/2"	15	55	85	16	0.26
112450RRW200606	112450FFW200606	3/4"	20	60	95	32	0.41
112450RRW200808	112450FFW200808	1"	25	65	115	52	0.61
112450RRW201010	112450FFW201010	1.1/4"	32	75	125	100	1.01
112450RRW201212	112450FFW201212	1.1/2"	40	80	145	172	1.16
112450RRW201616	112450FFW201616	2"	50	90	165	230	1.90
112450RRW202020*	112450FFW202020*	2.1/2"	65	100	210	-	3.68
112450RRW202424*	112450FFW202424*	3"	80	115	240	-	5.42
112450RRW203232*	112450FFW203232*	4"	100	135	290	-	10.59

*Valves available to special order.

Valve suitability

Product	Steam	Water	Drinking water	Oil	Air (oil free)	Gas (inert)	Gas (combustible)	Gas (corrosive)	Gas (oxygen)
1124	x	✓	✓	✓	x	x	x	x	x

Max. working parameters

1124	Temperature °C	Pressure bar	Pressure psi
Water	-10 to +100	20	290

Specification clauses:

- DZR brass gate valve.
- Non-rising stem.
- Handwheel operated.
- DZR brass threaded bonnet and one piece wedge.
- End connections, female taper threads to EN 10226-2 (ISO 7-1) and parallel threads to ISO 228.
- WRAS approved for drinking water systems.
- Suitable for low temperature hot water and chilled systems.

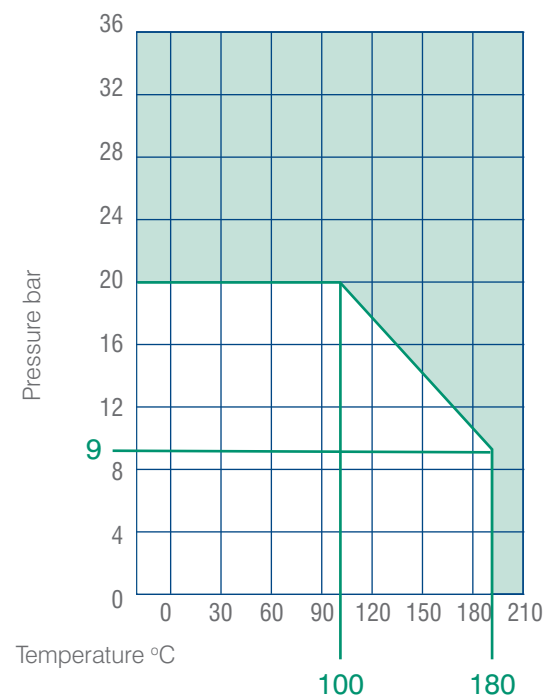

1124 Gate Valve Lockshield PN20 - (DZR)

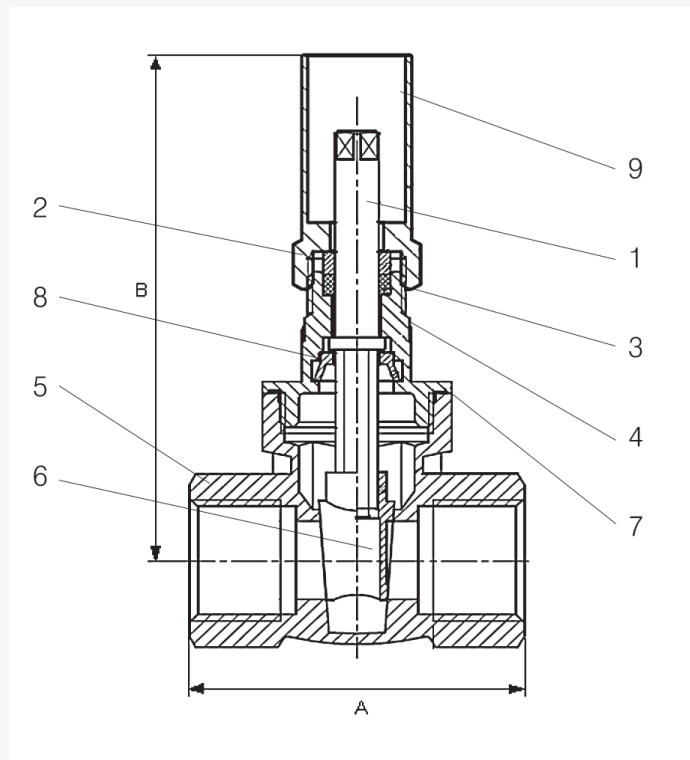

Material specification

1124 Lockshield version 1/2" to 4"

No	Component	Material	Specification
1	Stem	DZR brass	EN 12164 CW602N
2	Packing nut	Brass	EN 12164 CW614N
3	Packing	PTFE	PTFE
4	Bonnet	DZR brass	EN 12165 CW602N
5	Body	DZR brass	EN 12165 CW602N
6	Wedge	DZR brass	EN 12165 CW602N
7	Seal	PTFE	PTFE
8	Stem retainer	DZR brass	EN 12164 CW602N
9	Lockshield	Brass	EN 12164 CW614N

Gate valves are designed for services that only need infrequent operation, where the gate is maintained at either fully open or fully closed. They should not be used for throttling the flow of fluid.

Features and benefits:

- Non-rising stem.
- Lockshield key operated.
- End connections, female taper threads to EN 10226-2 (ISO 7-1) and parallel threads to ISO 228.
- Dezincification resistant brass prevents system.
- WRAS approved for drinking water systems, taper threads to EN 10226-2 (ISO 7-1).
- Suitable for use with low temperature hot water and chilled systems.

1124 Gate Valve

Order code EN 10226-2 (ISO 7-1) thread	Order code ISO 228 thread	Size	DN	A	B	Kv value	Weight (kg)
112450RRK200404	112450FFK200404	1/2"	15	55	85	16	0.26
112450RRK200606	112450FFK200606	3/4"	20	60	95	32	0.40
112450RRK200808	112450FFK200808	1"	25	65	110	52	0.57
112450RRK201010	112450FFK201010	1.1/4"	32	75	125	100	0.96
112450RRK201212	112450FFK201212	1.1/2"	40	80	145	172	1.13
112450RRK201616	112450FFK201616	2"	50	90	170	230	1.81
112450RRK202020*	112450FFK202020*	2.1/2"	65	100	210	-	3.68
112450RRK202424*	112450FFK202424*	3"	80	115	240	-	5.42
112450RRK203232*	112450FFK203232*	4"	100	135	290	-	10.59

*Valves available to special order.

A--GVLKKEY-- Lockshield key for valves 1/2" to 1"

B--GVLKKEY-- Lockshield key for valves 1.1/4" to 2"

Valve suitability

Product	Steam	Water	Drinking water	Oil	Air (oil free)	Gas (inert)	Gas (combustible)	Gas (corrosive)	Gas (oxygen)
1124	x	✓	✓	✓	x	x	x	x	x

Max. working parameters

1124	Temperature °C	Pressure bar	Pressure psi
Water	-10 to +100	20	290

Specification clauses:

- DZR brass gate valve.
- Non-rising stem.
- DZR threaded bonnet and one piece wedge.
- Lockshield key operated.
- End connections, female taper threads to EN 10226-2 (ISO 7-1) and parallel threads to ISO 228.
- WRAS approved for drinking water systems.
- Suitable for low temperature hot water and chilled systems.

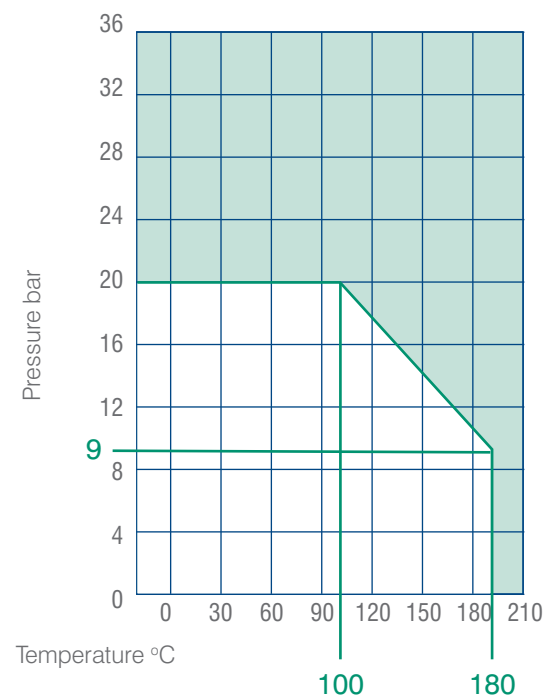

1126 Gate Valve Handwheel PN32 - (bronze)

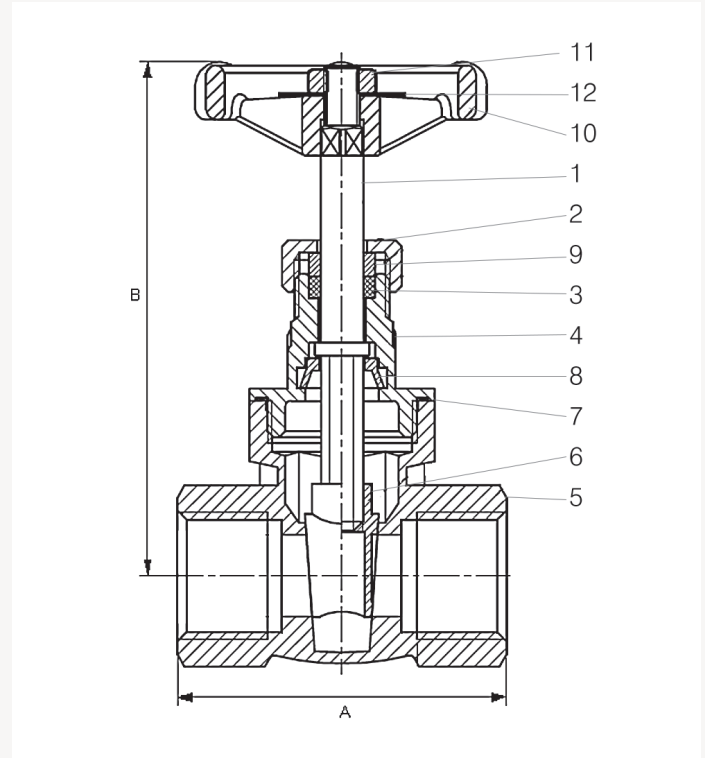

Material specification

1126 Lockshield version 1/2" to 4"

No	Component	Material	Specification
1	Stem	Bronze	EN 1982 CC491K
2	Packing nut	Brass	EN 12164 CW614N
3	Packing	PTFE	PTFE
4	Bonnet	Bronze	EN 1982 CC491K
5	Body	Bronze	EN 1982 CC491K
6	Wedge	Bronze	EN 1982 CC491K
7	Seal	PTFE	PTFE
8	Stem retainer	DZR brass	EN 12164 CW602N
9	Packing ring	Brass	EN 12164 CW614N
10	Handwheel	Aluminium	EN 1706 LM6
11	Handwheel nut	Brass	EN 12164 CW614N
12	Identity disc	Aluminium	EN 1706 LM6

Gate valves are designed for services that only need infrequent operation, where the gate is maintained at either fully open or fully closed. They should not be used for throttling the flow of fluid.

Features and benefits:

- Designed in accordance with EN 12288 requirements.
- High quality bronze construction immune to dezincification and stress corrosion cracking resistant.
- End connections, female taper threads to EN 10226-2 (ISO 7-1) and parallel threads to ISO 228.
- WRAS approved for drinking water systems.
- Suitable for use with low temperature hot water and chilled systems.
- Unique Conex Bänninger handwheel.

1126 Gate Valve

Order code EN 10226-2 (ISO 7-1) thread	Order code ISO 228 thread	Size	DN	A	B	Kv value	Weight (kg)
112620RRW320404	112620FFW320404	1/2"	15	55	85	16	0.36
112620RRW320606	112620FFW320606	3/4"	20	60	95	32	0.69
112620RRW320808	112620FFW320808	1"	25	70	115	52	1.02
112620RRW321010	112620FFW321010	1.1/4"	32	75	125	100	1.57
112620RRW321212	112620FFW321212	1.1/2"	40	80	145	172	2.44
112620RRW321616	112620FFW321616	2"	50	90	165	230	3.43
112620RRW322020*	112620FFW322020*	2.1/2"	65	100	210	-	-
112620RRW322424*	112620FFW322424*	3"	80	115	240	-	-
112620RRW323232*	112620FFW323232*	4"	100	135	290	-	-

*Valves available to special order.

Valve suitability

Product	Steam	Water	Drinking water	Oil	Air (oil free)	Gas (inert)	Gas (combustible)	Gas (corrosive)	Gas (oxygen)
1126	x	✓	✓	✓	x	x	x	x	x

Max. working parameters

1126	Temperature °C	Pressure bar	Pressure psi
Water	-10 to +100	32	460

Specification clauses:

- Bronze material in accordance with EN 1982.
- Designed in accordance to EN 12288 requirements.
- Handwheel operated.
- Non-rising stem.
- Bronze threaded bonnet and one piece wedge.
- End connections, female taper threads to EN 10226-2 (ISO 7-1) and parallel threads to ISO 228.
- Suitable for low temperature hot water and chilled systems.

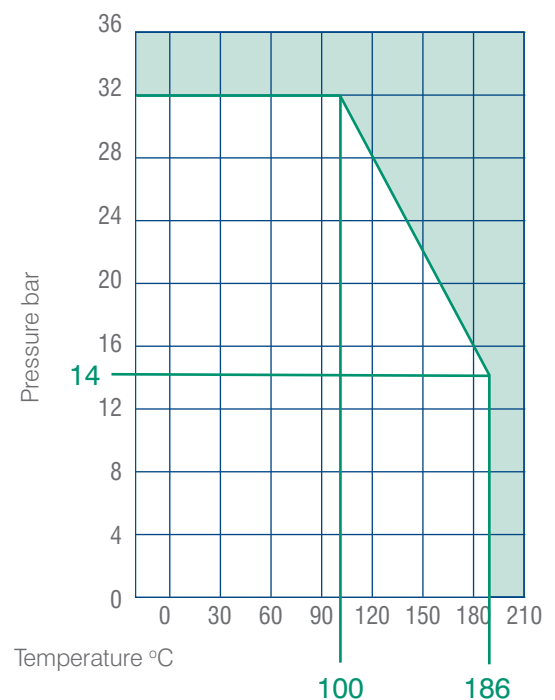

RVHX Resilient Seated Gate Valve PN16 flanged

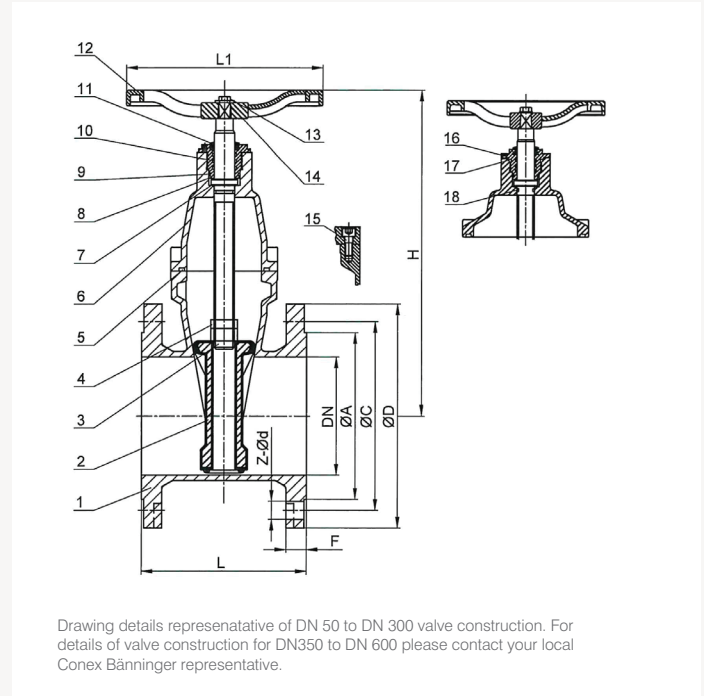

Drawing details representative of DN 50 to DN 300 valve construction. For details of valve construction for DN350 to DN 600 please contact your local Conex Bänninger representative.

Material specification

RVHX Resilient Seated Gate Valve Flanged 2" to 24"		
No	Component	Material
1	Body	Ductile iron
2	Wedge	Ductile iron + epdm
3	Stem	Stainless steel 2cr13
4	Stem nut	Manganese brass hmn58-2
5	Sealing ring	Epdm
6	Bonnet	Ductile iron
7	Gasket	Red brass c83600
8	Gland	Manganese brass hmn58-2
9	O-ring	Epdm
10	O-ring	Epdm
11	Dust ring	Epdm
12	Handwheel	Ductile iron
13	Bolt	Stainless steel ss304
14	Washer	Stainless steel ss304
15	Screw	High tensile steel 8.8
16	Screw	Stainless steel ss304
17	O-ring	Epdm
18	O-ring	Epdm

Material details representative of DN 50 to DN 300 valve construction for details of valve construction. For DN 350 to DN 600 please contact your local Conex Bänninger representative.

Applicable standards:

- Flanges comply with EN 1092-2.
- Valves comply with BS 5163.
- Face to face dimensions to EN 558-1 basic series 3.
- Pressure test complies with EN 12266-2003.

Technical data:

- Size: DN 50 - DN 600 (2" - 24").
- Nominal pressure: PN16.
- Shell test pressure: 24 bar.
- Seat test pressure: 17.6 bar.
- Temperature range: -5 °C to 85 °C.
- Suitable for water and neutral liquids.

Features and benefits:

- Available in sizes 2" - 24".
- Suitable for water and neutral liquids.
- Manufactured from high quality ductile iron.
- Ductile iron wedge encapsulated with vulcanised EPDM rubber for corrosion resistance.
- Electrostatically coated with corrosion resistant epoxy powder internally and externally. Minimum coating thickness 250 microns.
- Designed and manufactured in accordance with BS 5163.
- Handwheel operated.
- Designed with a non-rising stem to save installation space.

RVHX Resilient Seated Gate Valve Flanged 2" to 24"

Order Code	Size	DN	EN 1092-2 PN16							
			ØA	ØC	ØD	Z-Ød	F	L	L1	H
G0050CFDBH03DO	2"	50	99	125	165	4-Ø19	19	178	160	213
G0065CFDBH03DO	2 1/2"	65	118	145	185	4-Ø19	19	191	160	230
G0080CFDBH03DO	3"	80	132	160	200	8-Ø19	19	203	200	276
G0100CFDBH03DO	4"	100	156	180	220	8-Ø19	19	229	200	311
G0125CFDBH03DO	5"	125	184	210	250	8-Ø19	19	254	250	364
G0150CFDBH03DO	6"	150	211	240	285	8-Ø23	20	267	250	413
G0200CFDBH03DO	8"	200	266	295	340	12-Ø23	21	292	280	503
G0250CFDBH03DO	10"	250	319	355	405	12-Ø28	22	330	370	615
G0300CFDBH03DO	12"	300	370	410	460	12-Ø28	26.5	356	370	683
G0350CFDBH03DO	14"	350	429	470	520	16-Ø28	27	381	450	817
G0400CFDBH03DO	16"	400	480	525	580	16-Ø31	36.6	406	450	898
G0450CFDBH03DO	18"	450	548	585	640	20-Ø32	30	432	558	1009
G0500CFDBH03DO	20"	500	609	650	715	20-Ø34	34	457	610	1102
G0600CFDBH03DO	24"	600	720	770	840	20-Ø37	38	508	762	1283

Note: The torque required to operate the valve at the test pressure is less than that at nominal pressure thus ensuring that the valve is easy to operate.

RVCX Resilient Seated Gate Valve PN16 flanged

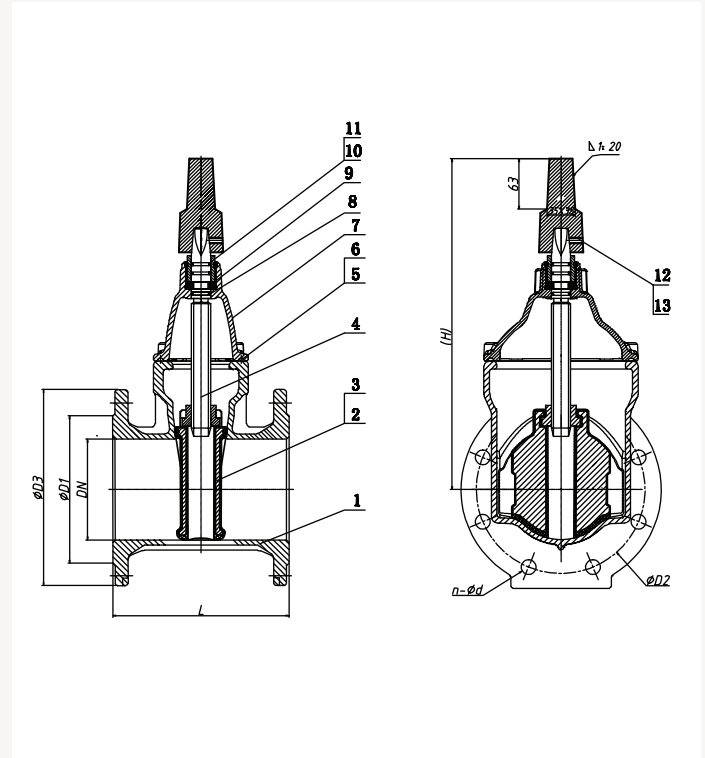

Material specification

RVCX Resilient Seated Gate Valve 2" to 12"

No	Component	Material
1	Body	Ductile iron GGG40
2	Wedge	Ductile iron GGG40 core fully encapsulated with EPDM rubber
3	Stem nut	Brass CZ132
4	Stem	316L stainless steel
5	Bonnet bolt	316 stainless steel
6	Bonnet gasket	EPDM rubber
7	Bonnet	Ductile iron GGG50
8	O-ring	Rubber NBR
9	Thrust collar	Brass CZ132
10	Gate bearing	Brass CW614
11	O-ring	Rubber NBR
12	Cap	Ductile iron GGG50
13	Bolt	316 stainless steel

Applicable standards:

- Flanges comply with EN 1092-2.
- Valves comply with BS 5163.
- Face to face dimensions to EN 558-1 basic series 3.
- Pressure test complies with EN 12266-2003.

Technical data:

- Size: DN 50 - DN 300 (2" - 12").
- Nominal pressure: PN16.
- Temperature range: 0 °C to 80 °C.
- Suitable for water and neutral liquids.

Features and benefits:

- WRAS approved for potable water applications.
- Available in sizes 2" - 12".
- Suitable for water and neutral liquids.
- Ductile iron wedge encapsulated with vulcanised EPDM rubber for corrosion resistance.
- Unique plastic guide rail in gate reduces friction and torque required to open / close valve.
- Manufactured from high quality ductile iron.
- Designed with 3 O-ring stem seal for zero leakage.

- Electrostatically coated with corrosion resistant epoxy powder internally and externally.
- Designed and manufactured in accordance with BS 5163.
- Designed with a non-rising stem to save installation space.
- Available with a stem cap for buried application.
- T-Key operated.

RVCX Resilient Seated Gate Valve

Order code option 1	Order code option 2	Size	DN	L mm	H mm	D1 mm	D2 mm	D3 mm	n-Ød mm	Weight (kg)
G0050CFDBT03DO	G0050CFDBT03DU	2"	50	178	325	99	125	165	4-19	8.6
G0065CFDBT03DO	G0065CFDBT03DU	2.1/2"	65	190	360	118	145	185	4-19	11.5
G0080CFDBT03DO	G0080CFDBT03DU	3"	80	203	390	132	160	200	8-19	14
G0100CFDBT03DO	G0100CFDBT03DU	4"	100	229	430	156	180	220	8-19	18.3
G0125CFDBT03DO	G0125CFDBT03DU	5"	125	254	460	184	210	250	8-19	22
G0150CFDBT03DO	G0150CFDBT03DU	6"	150	267	540	211	240	285	8-23	30
G0200CFDBT03DO	G0200CFDBT03DU	8"	200	292	600	266	295	340	12-23	46.5
G0250CFDBT03DO	G0250CFDBT03DU	10"	250	330	740	319	355	405	12-28	78
G0300CFDBT03DO	G0300CFDBT03DU	12"	300	356	800	370	410	460	12-28	110.5

Option 1: RVCX - standard product **Option 2:** RVCX - version for UAE

Tested torque values at nominal pressure and test pressure of 1.1 X nominal pressure

Nominal diameter	Nominal pressure	Test pressure (1.1 X nominal pressure)
	Torque Nm	Torque Nm
DN 50	50	50
65	60	60
80	75	75
100	100	100
125	125	125
150	150	150
200	200	200
250	250	250
300	300	300

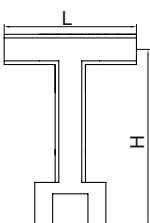

T-key operated:

The T-key's are designed according to BS 5163. To avoid damaging a valve by applying excessive torque when using a T-key please check the dimensions (length and height) are in line with those listed in the table below.

Nominal diameter	DN50 DN200	DN250 DN600
T-key lever length L	≤ 300mm	≤ 550mm
T-key lever height H	≤ 1000mm	≤ 1000mm

T-key lever

RVHX F4 Resilient Seated Gate Valves PN16 flanged

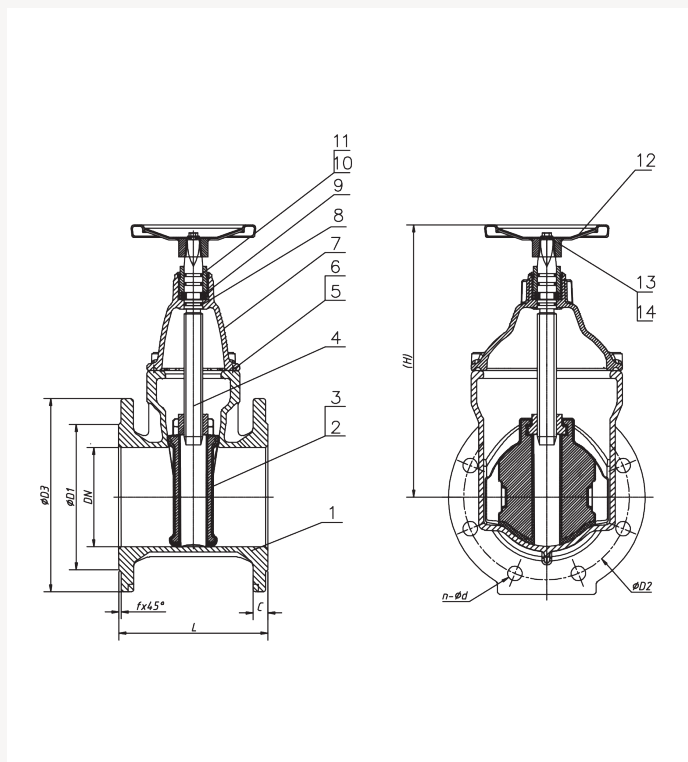

Material specification

RVHX F4 Resilient Seated Gate Valves 2" to 12"

No	Component	Material
1	Body	Cast iron GGG40
2	Wedge	Cast iron GGG40, core fully encapsulated with EPDM rubber
3	Stem nut	Brass CW614
4	Stem	420 stainless steel
5	Bonnet bolt	Zinc coated steel 8.8 sealed with hot melt
7	Bonnet	Cast iron GGG40
6	Bonnet sealing	Rubber EPDM
8	O-ring	Rubber EPDM
9	Thrust collar	Brass CW614
10	Gate bearing	Brass CW614
11	O-ring	Rubber EPDM
12	Handwheel	Steel plate punched
13	Bolt	Zinc coated steel 8.8 sealed with hot melt
14	Washer	Zinc coated steel sealed with hot melt

Notes: The valve will be operated by a handwheel, the standard direction of opening is counter-clockwise as viewed from the top of the valve.

Applicable standards:

- Flanges comply with EN 1092-2.
- Valves comply with DIN 3352-4.
- Face to face dimensions to DIN 3202 F4.
- Pressure test complies with EN 12266.

Technical data:

- Size: D N50 - DN 300 (2" - 12").
- Nominal pressure: PN16.
- Temperature range: 0 °C to 80 °C.
- Suitable for water and neutral liquids.

Features and benefits:

- WRAS approved for potable water applications.
- Available in sizes 2" - 12".
- Suitable for water and neutral liquids.
- Unique plastic guide rail in gate reduces friction and torque required to open / close valve.
- Manufactured from high quality ductile iron.
- Designed with three O-ring seals for zero leakage.
- Ductile iron wedge encapsulated with vulcanised EPDM rubber for corrosion resistance.
- Electrostatically coated with corrosion resistant epoxy powder internally and externally.
- Designed and manufactured in accordance with DIN 3352-4.
- Designed with a non-rising stem to save installation space.
- Handwheel operated.

RVHX F4 Resilient Seated Gate Valves

Order code	Size	DN	L mm	H mm	D1 mm	D2 mm	D3 mm	f mm	C mm	n-Ød mm	Weight (kg)
G0050CFD4H14DO	2"	50	178	220	99	125	165	3	19	4-19	7.6
G0065CFD4H14DO	2 1/2"	65	190	240	118	145	185	3	19	4-19	10.5
G0080CFD4H14DO	3"	80	203	290	132	160	200	3	19	8-19	13
G0100CFD4H14DO	4"	100	229	330	156	180	220	3	19	8-19	17.3
G0125CFD4H14DO	5"	125	254	375	184	210	250	3	19	8-19	21
G0150CFD4H14DO	6"	150	267	420	211	240	285	3	19	8-23	29
G0200CFD4H14DO	8"	200	292	500	266	295	340	3	20	12-23	45.5
G0250CFD4H14DO	10"	250	330	610	319	355	405	3	22	12-28	75.4
G0300CFD4H14DO	12"	300	356	720	370	410	460	4	24.5	12-28	106

Tested torque values at nominal pressure and test pressure of 1.1 X nominal pressure

Nominal diameter	Nominal pressure	Test pressure (1.1 X nominal pressure)
DN	Torque Nm	Torque Nm
50	50	40
65	60	50
80	75	60
100	100	80
125	125	100
150	150	120
200	200	160
250	250	200
300	300	240

Note: The torque required to operate the valve at the test pressure is less than that at nominal pressure thus ensuring that the valve is easy to operate.

RVRX Resilient Seated Gate Valve PN16 flanged

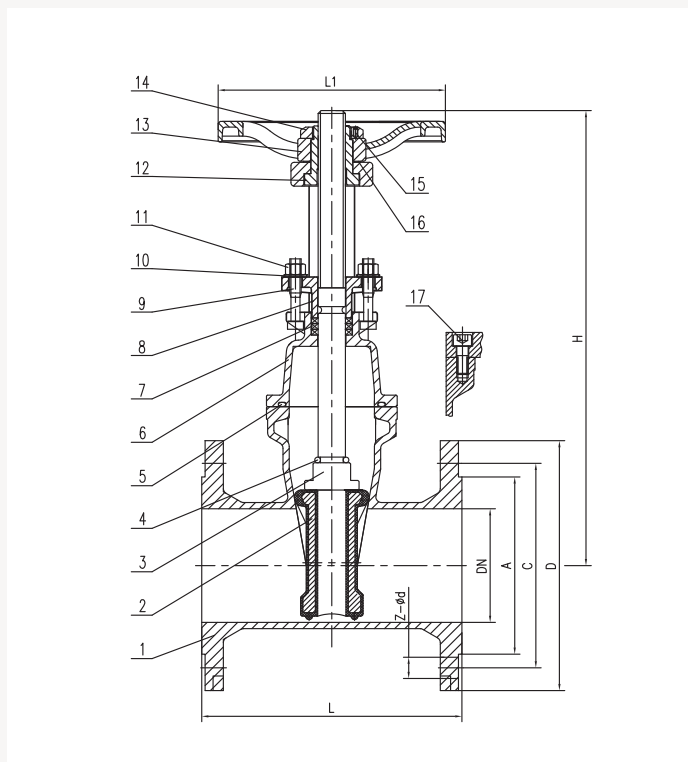

Material specification

RVRX Resilient Seated Gate Valve Flanged 2" to 24"

No	Component	Material
1	Body	Ductile iron
2	Wedge	Ductile iron + EPDM
3	Stem	Stainless steel SS420
4	O-ring	EPDM
5	Seal ring	Flexible graphite +304
6	Bonnet	Cast iron QT450-10
7	Packing	Flexible graphite +304
8	Gland	Cast iron QT450-10
9	Square head bolt	Stainless steel SS304
10	Flat washer	Stainless steel SS304
11	Nut	Stainless steel SS201
12	Stem nut	Manganese brass HMn58-2
13	Handwheel	Cast iron QT450-10
14	Lock nut	Stainless steel SS304
15	Screw	Stainless steel SS304
16	Washer	Bronze C83600
17	Screw	High tensile steel Gr 8.8

Applicable standards:

- Flanges comply with EN 1092-2.
- Valves comply with BS 5163.
- Face to face dimensions to EN 558-1 basic series 3.
- Pressure test complies with EN 12266-2003.

Technical data:

Size: DN 50 - DN 600 (2" - 12").

Working pressure: 16 bar.

Test pressure shell: 24 bar.

Test pressure seal: 17.6 bar.

Working temperature: -20 °C to 110 °C.

Features and benefits:

- Available in sizes 2" - 12".
- Suitable for water and neutral liquids.
- Manufactured from high quality ductile iron.
- Ductile iron wedge encapsulated with vulcanised EPDM rubber for corrosion resistance.
- Electrostatically coated with corrosion resistant epoxy powder internally and externally. Minimum coating thickness 250 microns.
- Handwheel operated.

RVRX Resilient Seated Gate Valve Flanged 2" to 12"

Order code	Size	DN	A	C	D	L	L1	H	Z-Ød
G0050CFDEH03DO	2"	50	99	125	165	178	160	253	4-Ø19
G0065CFDEH03DO	2 1/2"	65	118	145	185	190	160	295	4-Ø19
G0080CFDEH03DO	3"	80	132	160	200	203	200	356	8-Ø19
G0100CFDEH03DO	4"	100	156	180	220	229	200	411	8-Ø19
G0125CFDEH03DO	5"	125	184	210	250	254	250	489	8-Ø19
G0150CFDEH03DO	6"	150	211	240	285	267	250	563	8-Ø23
G0200CFDEH03DO	8"	200	266	295	340	292	280	704	12-Ø23
G0250CFDEH03DO	10"	250	319	355	405	330	370	855	12-Ø28
G0300CFDEH03DO	12"	300	370	410	460	356	370	995	12-Ø28

2.0 Butterfly Valves

Conex Bänninger offers a wide range of butterfly valves made from high quality ductile iron. Butterfly valves are part of the quarter turn valve family and are used to isolate or regulate fluid flow within a pipeline. Butterfly valves are a light-weight cost-effective choice. Wafer, lugged or flanged variants are available. All Conex Bänninger Butterfly Valves are electrostatically coated with epoxy powder internally and externally for corrosion resistance. Conex Bänninger Butterfly Valves are designed for use with water or neutral fluids.

Features and benefits include:

- Manufactured from high quality ductile iron.
- Electrostatically coated with corrosion resistant epoxy powder internally and externally.
- Concentric and eccentric designs.
- Wafer pattern for quick installation, lug pattern and flanged connections for high pressure installations.
- Streamlined discs for low head loss.
- Closure via lever, handwheel and electric actuator.
- Conex Bänninger Butterfly Valves are suitable for use with water and neutral liquids.





BWLX Wafer Concentric Butterfly Valve PN16

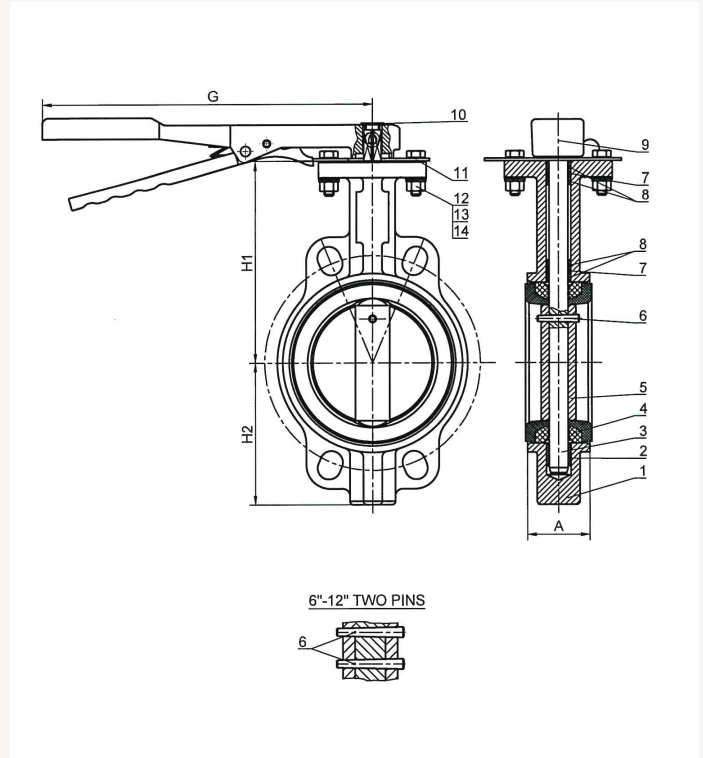

Material specification

BWLX Wafer Concentric Butterfly Valve 2" to 6"			
No	Component	Material	
1	Body	Ductile iron	
2	Bushing	PTFE	
3	Shaft	Stainless steel SS410	
4	Seat	EPDM	
5	Disc	CF8/DI*/CF8M*/C94500*	
6	Pin	Stainless steel SS316	
7	O-ring	EPDM	
8	Bushing	PTFE	
9	Lever	Malleable iron	
10	Plastic cover	ABS	
11	Notch plate	Stainless steel SS304	
12	Bolt	Carbon steel	
13	Flat washer	Carbon steel	
14	Spring washer	Spring steel 65 Mn	

*Variants available to special order. Please contact your local Conex Bänninger representative.

Applicable standards:

- Design standard: EN 593 / BS 5155 / MSS SP-67 / AP1 609.
- Connection standard: EN 1092-2.
- Face to face standard: EN 558-1 basic series 20.
- Top flange standard: ISO 5211-1.

Technical data:

- Size: DN 50 - DN 150 (2" - 16").
- Nominal pressure: PN16.
- Test pressure shell: 24 bar.
- Test pressure seal: 17.6 bar.
- Temperature range: -10 °C to 80 °C (NBR O-ring), -20 °C to 110 °C (EPDM O-ring).
- Suitable for water and neutral liquids.

Features and benefits:

- Wafer pattern design, for quick installation.
- Lug pattern design, for high-pressure applications.
- Replaceable wide EPDM seat suitable for variety of flange types.
- Bi directional shut off seat prevents backflow within the pipeline.
- Streamlined stainless steel disc ensures lower water head loss.
- Manufactured from high quality ductile iron.
- Electrostatically coated with corrosion resistant epoxy powder internally and externally. Minimum coating thickness 250 microns.
- Low torque lever operation.

BWLX Wafer Concentric Butterfly Valve 2" to 6"

Order	Size	DN	H1	H2	A	G
B0050CWCNL20SO	2"	50	141.2	68.6	42	195/266
B0065CWCNL20SO	2 1/2"	65	150.4	76	44.5	195/266
B0080CWCNL20SO	3"	80	156.4	98.6	44.5	195/266
B0100CWCNL20SO	4"	100	167.9	118.7	51	266
B0125CWCNL20SO	5"	125	186.5	129.4	54.5	266
B0150CWCNL20SO	6"	150	205.7	142	54.5	328

Variants with DI/CF8M/C94500 disc available to special order. Please contact your local Conex Bänninger representative.

BWLX Wafer Concentric Butterfly Valve 2" to 6"

Kv Values - Valve Sizing Coefficients (m³/h@1bar) DN50 to DN150

Size	DN	10°	20°	30°	40°	50°	60°	70°	80°	90° Fully Open
2"	50	0.1	4.3	10.3	20.6	38.6	54.8	77.1	107.1	115.7
2 1/2"	65	0.2	6.9	17.1	31.7	55.7	84.0	123.4	174.8	188.5
3"	80	0.3	10.3	18.9	33.4	60.0	99.4	156.8	235.6	258.8
4"	100	0.4	14.6	30.8	66.8	119.1	197.1	311.9	467.9	514.1
5"	125	0.7	24.9	52.3	114.0	203.1	335.9	531.3	796.9	875.7
6"	150	1.7	38.6	81.4	175.7	313.6	518.4	820.9	1231.4	1353.0

BWGX Wafer Concentric Butterfly Valve PN16

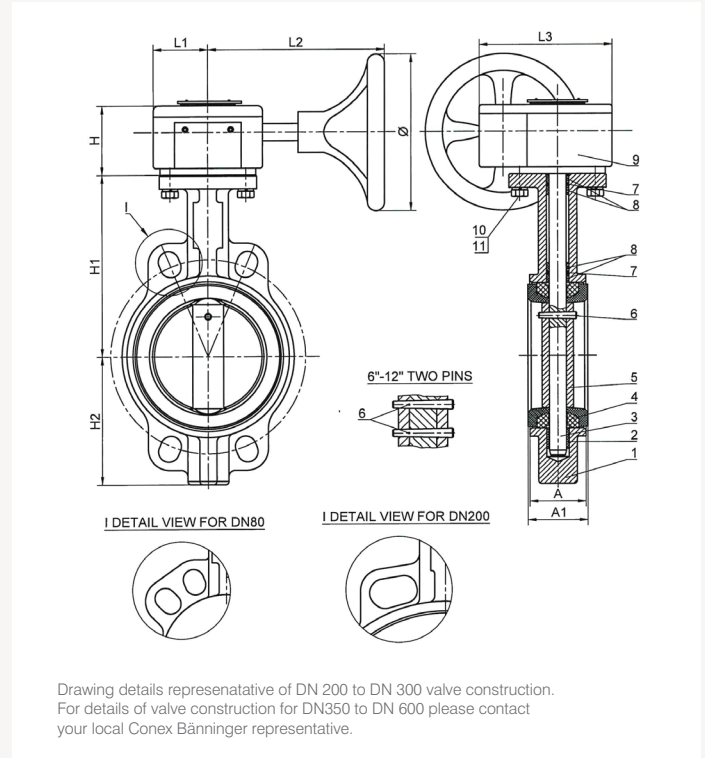

Material specification

BWGX Wafer Concentric Butterfly Valve 8" to 24"		
No	Component	Material
1	Body	Ductile iron
2	Bushing	PTFE
3	Shaft	Stainless steel SS410
4	Seat	EPDM
5	Disc	CF8/DI*/CF8M*/C94500*
6	Pin	Stainless steel SS316
7	O-ring	EPDM
8	Bushing	PTFE
9	Gearbox	Cast iron
10	Bolt	Carbon steel
11	Spring washer	Spring steel 65 Mn

*Variants available to special order. Please contact your local Conex Bänninger representative.

Material details representative of DN 200 to DN 300 valve construction. For details of valve construction for DN350 to DN 600 please contact your local Conex Bänninger representative.

Applicable standards:

- Design standard: EN 593 / BS 5155 / MSS SP-67 / AP1 609.
- Connection standard: EN 1092-2.
- Face to face standard: EN 558-1 basic series 20.
- Top flange standard: ISO 5211-1.

Technical data:

- Size: DN 200 – DN 600 (8" - 24").
- Nominal pressure: PN16.
- Test pressure shell: 24 bar.
- Test pressure seal: 17.6 bar.
- Temperature range: -20 °C to 110 °C
- Suitable for water and neutral liquids.

Features and benefits:

- Wafer pattern design, for quick installation.
- Replaceable wide EPDM seat suitable for variety of flange types.
- Bi directional shut off seat prevents backflow within the pipeline.
- Streamlined stainless steel disc ensures lower water head loss.
- Manufactured from high quality ductile iron.
- Electrostatically coated with corrosion resistant epoxy powder internally and externally. Minimum coating thickness 250 microns.
- Handwheel operation.

BWGX Wafer Concentric Butterfly Valve 8" to 24"

Order code	Size	DN	H1	H2	A	A1	L1	L2	L3	H	Ø
B0200CWCNG20SO	8"	200	230.6	176	59.6	64.1	75	208	171	80	280
B0250CWCNG20SO	10"	250	269.9	208.8	67	71.8	75	208	171	80	280
B0300CWCNG20SO	12"	300	327.8	248.5	75.5	79.5	80	212	198	80	280
B0350CWCNG20SO	14"	350	368	272	75.5	-	80	267	198	80	280
B0400CWCNG20SO	16"	400	400	333	102	-	125	275	280	99	400
B0450CWCNG20SO	18"	450	422	364	114	-	125	275	280	99	400
B0500CWCNG20SO	20"	500	480	389	127	-	130	350	316	150	400
B0600CWCNG20SO	24"	600	-	-	-	-	-	-	-	-	-

Note: For dimensional details of DN 600 please contact your local Conex Bänninger representative.

Variants with DI/CF8M/C94500 disc available to special order, please contact your local Conex Bänninger representative.

BWGX Wafer Concentric Butterfly Valve 8" to 24"

Kv Values - Valve Sizing Coefficients (m³/h@1bar) DN50 to DN150

Size	DN	10°	20°	30°	40°	50°	60°	70°	80°	90° Fully Open
8"	200	2.6	76.3	161.1	349.6	623.0	1030.0	1630.7	2445.6	2687.2
10"	250	3.4	129.4	274.2	594.7	1060.0	1754.1	2776.3	4163.7	4575.8
12"	300	4.3	200.5	424.2	918.6	1637.5	2709.5	4288.8	6432.7	7069.4
14"	350	5.1	289.6	612.7	1327.3	2365.9	3914.3	6195.4	9292.7	10211.7
16"	400	6.9	397.6	842.3	1825.2	3253.6	5383.0	8519.3	12778.9	14042.8
18"	450	9.4	527.0	1115.7	2418.2	4308.5	7129.4	11283.6	16925.4	18599.0
20"	500	12.0	677.8	1434.4	3108.8	5539.8	9167.1	14508.1	21761.8	23914.3
24"	600	18.9	1047.1	2216.8	4802.9	8559.6	14162.8	22413.9	33621.8	36946.0

BLLX Lug Concentric Butterfly Valve PN16

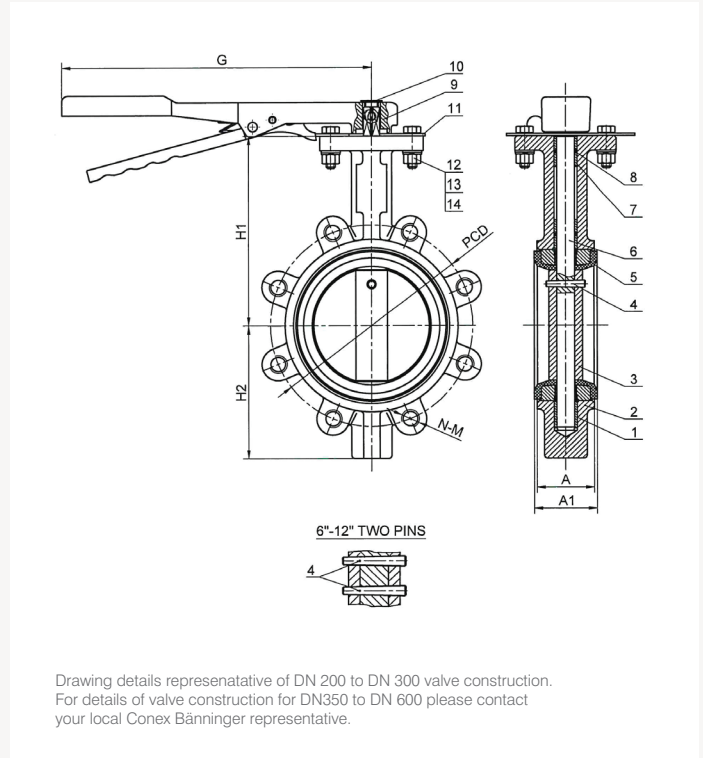

Material specification

BLLX Lug Concentric Butterfly Valve 2" to 6"		
No	Component	Material
1	Bushing	PTFE
2	Body	Ductile iron
3	Disc	CF8/DI*/CF8M*/C94500*
4	Pin	Stainless steel SS316
5	Seat	EPDM
6	Shaft	Stainless steel SS410
7	Bushing	PTFE
8	O-ring	EPDM
9	Lever	Malleable iron
10	Plastic cover	ABS
11	Notch plate	Stainless steel SS304
12	Bolt	Carbon steel
13	Flat washer	Carbon steel
14	Spring washer	Spring steel 65 Mn

*Variants available to special order please contact your local Conex Bänninger representative.

Applicable standards:

- Design standard: EN 593 / BS 5155 / MSS SP-67 / API 609.
- Connection standard: EN1092-2.
- Face to face dimensions according to EN 558-1 basic series 20.
- Top flange standard: ISO 5211-1.

Technical data:

- Size: DN 50 – DN 300 (2" - 6").
- Nominal pressure: PN16.
- Test pressure shell: 24 bar.
- Test pressure seal: 17.6 bar.
- Temperature range: -20 °C to 110 °C.
- Suitable for water and neutral liquids.

Features and benefits:

- Lug pattern designed for high-pressure applications.
- Replaceable wide EPDM seat suitable for variety of flange type.
- Bi-directional shut-off seat prevents backflow within the pipeline.
- Streamlined stainless steel disc ensures lower water head loss.
- Manufactured from high quality ductile iron.
- Electrostatically coated with corrosion resistant epoxy powder internally and externally. Minimum coating thickness 250 microns.
- Lever operated.

BLLX Lug Concentric Butterfly Valve 2" to 6"

Order Code	Size	DN	H1	H2	A	A1	G
B0050CLCNG20SO	2"	50	141.2	68.6	42	46.1	195/266
B0065CLCNG20SO	2 1/2"	65	150.4	76	44.5	49.1	195/266
B0080CLCNG20SO	3"	80	156.4	98.6	44.5	49.1	195/266
B0100CLCNG20SO	4"	100	167.9	118.7	51	55.5	266
B0125CLCNG20SO	5"	125	186.5	129.4	54.5	58.8	266
B0150CLCNG20SO	6"	150	205.7	142	54.5	59.1	328

Variants with DI/CF8M/C94500 disc available to special order please contact your local Conex Bänninger representative.

BLLX Lug Concentric Butterfly Valve 2" to 6"

Kv Values - Valve Sizing Coefficients (m³/h@1bar) DN50 to DN 150

Size	DN	10°	20°	30°	40°	50°	60°	70°	80°	90° Fully Open
2"	50	0.1	4.3	10.3	20.6	38.6	54.8	77.1	107.1	115.7
2 1/2"	65	0.2	6.9	17.1	31.7	55.7	84.0	123.4	174.8	188.5
3"	80	0.3	10.3	18.9	33.4	60.0	99.4	156.8	235.6	258.8
4"	100	0.4	14.6	30.8	66.8	119.1	197.1	311.9	467.9	514.1
5"	125	0.7	24.9	52.3	114.0	203.1	335.9	531.3	796.9	875.7
6"	150	1.7	38.6	81.4	175.7	313.6	518.4	820.9	1231.4	1353.0

BLGX Lug Concentric Butterfly Valve PN16

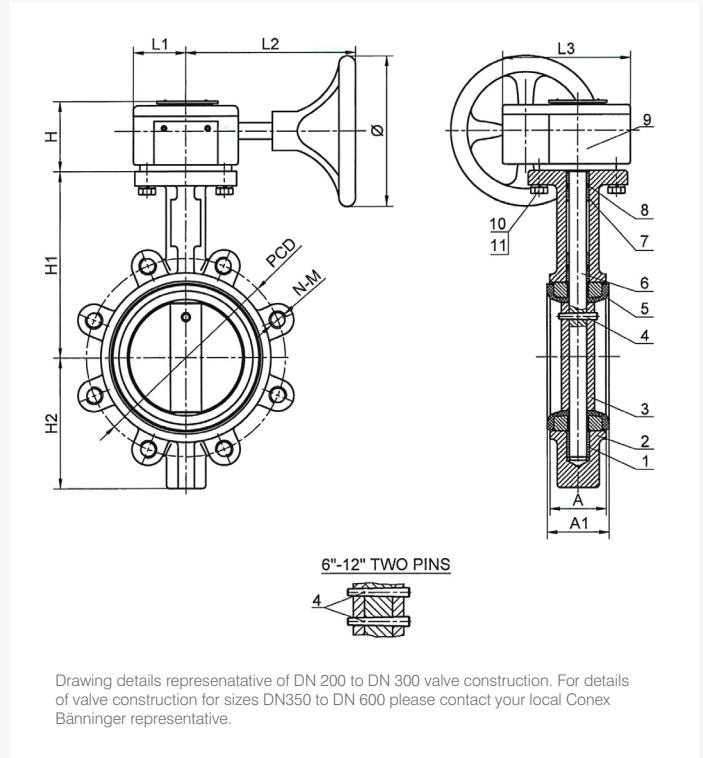

Material specification

BLGX Wafer Concentric Butterfly Valve 8" to 24"			
No	Component	Material	
1	Bushing	PTFE	
2	Body	Ductile iron	
3	Disc	CF8/DI*/CF8M*/C94500*	
4	Pin	Stainless steel SS316	
5	Seat	EPDM	
6	Shaft	Stainless steel SS410	
7	Bushing	PTFE	
8	O-ring	EPDM	
9	Gearbox	Cast iron	
10	Bolt	Carbon steel	
11	Spring washer	Spring steel 65 Mn	

*Variants available to special order please contact your local Conex Bänninger representative.

Material details representative of DN 200 to DN 300 valve construction. For details of valve construction for sizes DN350 to DN 600 please contact your local Conex Bänninger representative.

Applicable standards:

- Design standard: EN 593 / BS 5155 / MSS SP-67 / API 609.
- Connection standard: EN 1092-2.
- Face to face standard: EN 558-1 basic series 20.
- Top flange standard: ISO 5211-1.

Technical data:

- Size: DN 50 - DN 150 (8" - 24").
- Nominal pressure: PN16.
- Test pressure: shell 24 bar.
- Test pressure: seal 17.6 bar.
- Temperature range: -20 °C to 110 °C.
- Suitable for water and neutral liquids.

Features and benefits:

- Lug pattern design, for high-pressure applications.
- Replaceable wide EPDM seat suitable for variety of flange types.
- Bi directional shut off seat prevents backflow within the pipeline.
- Streamlined stainless steel disc ensures lower water head loss.
- Manufactured from high quality ductile iron.
- Electrostatically coated with corrosion resistant epoxy powder internally and externally. Minimum coating thickness 250 microns.
- Operated by handwheel.

BLGX Wafer Concentric Butterfly Valve 8" to 24"

Order Code	Size	DN	H1	H2	A	A1	L1	L2	L3	H	Ø
B0200CWCNG2060	8"	200	230.6	176	59.6	64.1	75	208	171	80	280
B0250CWCNG2060	10"	250	269.9	208.8	67	71.8	75	208	171	80	280
B0300CWCNG2060	12"	300	327.8	248.5	75.5	79.5	80	212	198	80	280
B0350CWCNG2060	14"	350	368	267	76	-	80	212	198	80	280
B0400CWCNG2060	16"	400	400	309	102	-	125	275	280	99	400
B0450CWCNG2060	18"	450	422	327	114	-	125	275	280	99	400
B0500CWCNG2060	20"	500	480	361	127	-	130	350	316	150	400
B0600CWCNG2060	24"	600	562	459	151	-	130	350	316	150	400

Variants with DI/CF8M/C94500 disc available to special order please contact your local Conex Bänninger representative.e.

BLGX Wafer Concentric Butterfly Valve 8" to 24"

Kv Values - Valve Sizing Coefficients (m³/h@1bar) DN200 to DN600

Size	DN	10°	20°	30°	40°	50°	60°	70°	80°	90° Fully Open
8"	200	2.6	76.3	161.1	349.6	623.0	1030.0	1630.7	2445.6	2687.2
10"	250	3.4	129.4	274.2	594.7	1060.0	1754.1	2776.3	4163.7	4575.8
12"	300	4.3	200.5	424.2	918.6	1637.5	2709.5	4288.8	6432.7	7069.4
14"	350	5.1	289.6	612.7	1327.3	2365.9	3914.3	6195.4	9292.7	10211.7
16"	400	6.9	397.6	842.3	1825.2	3253.6	5383.0	8519.3	12778.9	14042.8
18"	450	9.4	527.0	1115.7	2418.2	4308.5	7129.4	11283.6	16925.4	18599.0
20"	500	12.0	677.8	1434.4	3108.8	5539.8	9167.1	14508.1	21761.8	23914.3
24"	600	18.9	1047.1	2216.8	4802.9	8559.6	14162.8	22413.9	33621.8	36946.0

BZGX Flanged Concentric Butterfly Valve PN16

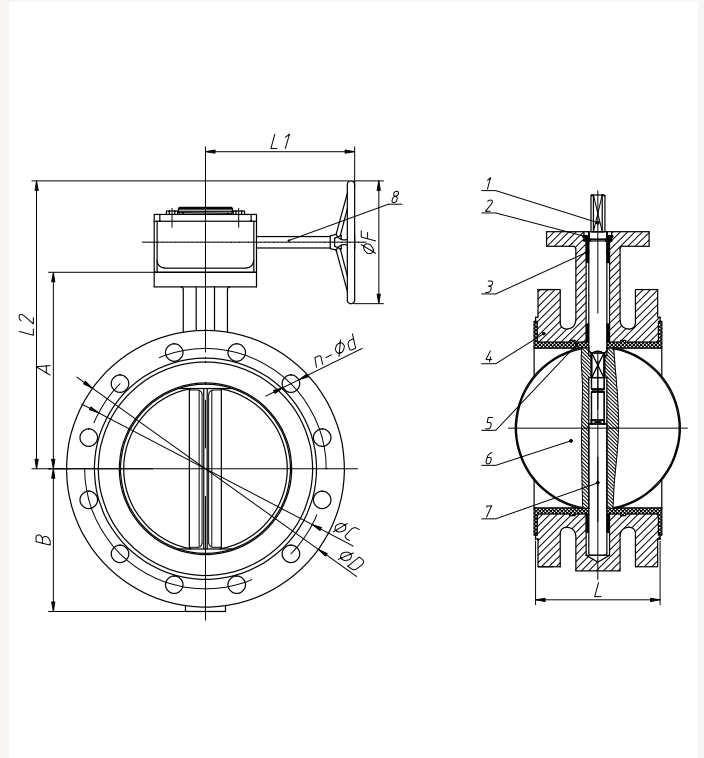

Material specification

BZGX Flanged Concentric Butterfly Valve 2" to 24"

No	Component	Material
1	Upper stem	420 stainless steel
2	Washer	65 Mn spring steel
3	O-ring	Rubber EPDM
4	Body	Ductile iron GGG40
5	Seat	Rubber EPDM
6	Disc	Option 1: 304 SS, handwheel operated Option 2: aluminium bronze with epoxy coating, T key operated Option 3: 316 SS, T key operated Option 4: 316 SS, operation bare stem
7	Lower stem	420 stainless steel
8	Gearbox	Rotork

Butterfly Valves

Applicable standards:

- Design standard EN 593.
- Flange connection standard EN1092-2.
- Top flange dimensions standard ISO 5211.
- Face to face dimensions standard EN 558-1 basic series 13.
- Pressure test standard EN 12266-1.

Technical data:

- Size: DN 50 - DN 600 (2" - 24").
- Nominal pressure: PN16.
- Temperature range: -5 °C to 85 °C.
- Suitable for water and neutral liquids.

Features and benefits:

- Flange type pattern design.
- Low torque operation.
- Designed with a bi-directional shut-off seat.
- Available in sizes 2" - 24".
- Manufactured from high quality ductile iron.
- Electrostatically coated with corrosion resistant epoxy powder internally and externally.
- Streamlined disc reduces head loss.
- Suitable for water and neutral liquids.
- Designed to facilitate easy mounting of hand gears and electric actuators.
- Valve seat fully vulcanized EPDM.
- Available with handwheel and gear operation.

Opening - Kv value curve

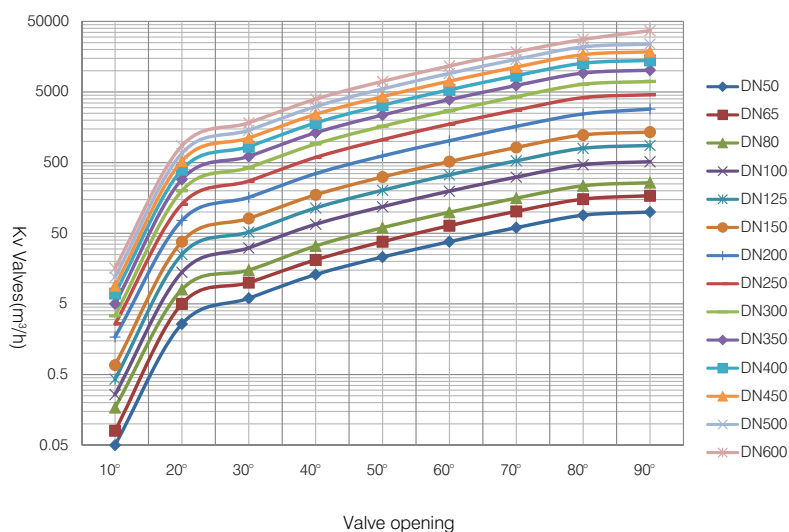

BZGX Flange Concentric Butterfly Valves

Order code option 1	Order code option 2	Order code option 3	Order code option 4	Size	DN	A mm	B mm	L mm	L2 mm	L1 mm	ØD mm	ØC mm	mm n-Ød mm	ØF mm	Weight (kg)
B0050CFDCG13SO	B0050CFDCG13SU	B0050CFDCG136U	B0050CFDCN136U	2"	50	131	83.25	108	220.5	155	165	125	4-M19	125	8.6
B0065CFDCG13SO	B0065CFDCG13SU	B0065CFDCG136U	B0065CFDCN136U	2.1/2"	65	142	85	112	231.5	155	185	145	4-M19	125	10.5
B0080CFDCG13SO	B0080CFDCG13SU	B0080CFDCG136U	B0080CFDCN136U	3"	80	155	92.5	114	244.5	155	200	160	8-M19	125	11.4
B0100CFDCG13SO	B0100CFDCG13SU	B0100CFDCG136U	B0100CFDCN136U	4"	100	168	108.5	127	257.5	155	220	180	8-M19	125	14.6
B0125CFDCG13SO	B0125CFDCG13SU	B0125CFDCG136U	B0125CFDCN136U	5"	125	184	121.5	140	273.5	155	250	210	8-M19	125	19.0
B0150CFDCG13SO	B0150CFDCG13SU	B0150CFDCG136U	B0150CFDCN136U	6"	150	202	138	140	291.5	155	285	240	8-M23	125	22.5
B0200CFDCG13SO	B0200CFDCG13SU	B0200CFDCG136U	B0200CFDCN136U	8"	200	241	161.5	152	369	170	340	295	8-M23	200	33.4
B0250CFDCG13SO	B0250CFDCG13SU	B0250CFDCG136U	B0250CFDCN136U	10"	250	272	195	165	400	170	405	355	12-M23	200	46.3
B0300CFDCG13SO	B0300CFDCG13SU	B0300CFDCG136U	B0300CFDCN136U	12"	300	308	222	178	436	170	460	410	12-M28	250	59.5
B0350CFDCG13SO	B0350CFDCG13SU	B0350CFDCG136U	B0350CFDCN136U	14"	350	330	250	190	520.5	250	520	470	16-M28	300	90.6
B0400CFDCG13SO	B0400CFDCG13SU	B0400CFDCG136U	B0400CFDCN136U	16"	400	375	292	216	565.5	292	580	525	16-M28	300	115.0
B0450CFDCG13SO	B0450CFDCG13SU	B0450CFDCG136U	B0450CFDCN136U	18"	450	405	307	222	647	307	640	585	16-M31	400	161.0
B0500CFDCG13SO	B0500CFDCG13SU	B0500CFDCG136U	B0500CFDCN136U	20"	500	450	342	229	692	342	715	650	20-M34	400	179.0
B0600CFDCG13SO	B0600CFDCG13SU	B0600CFDCG136U	B0600CFDCN136U	24"	600	518	433	267	816	433	840	770	20-M37	500	257.0

Option 1: BZGX Disc 304 SS, handwheel operated | **Option 2:** BZGX - Disc aluminium bronze with epoxy coating, T key operated

Option 3: BZGX - Disc 316 SS, T key operated | **Option 4:** BZGX - Disc 316 SS, operation bare stem

BFGX Flanged Eccentric Butterfly Valve PN10

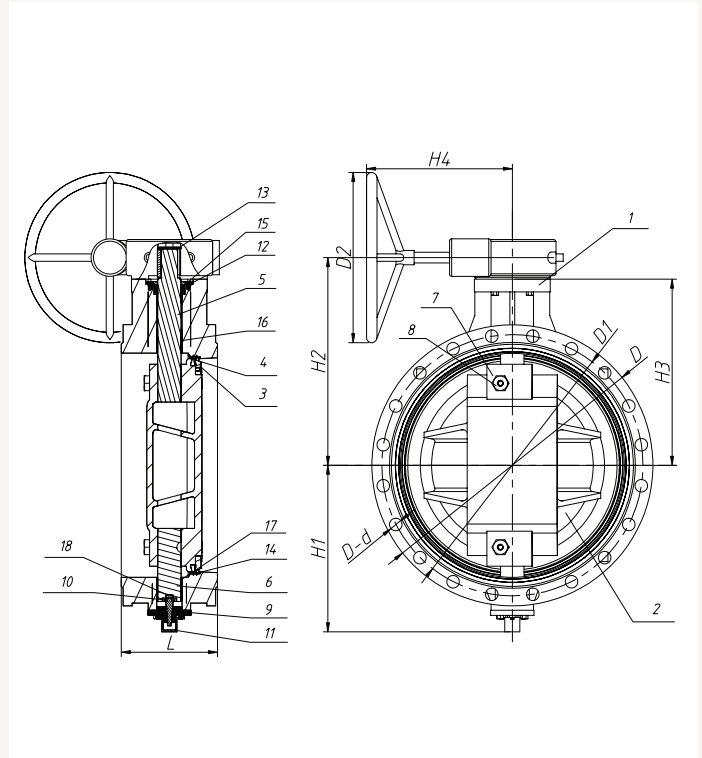

Material specification

BFGX Flanged Eccentric Butterfly Valve 14" to 48"

No	Component	Material
1	Body	Ductile iron GGG40
2	Disc	Ductile iron GGG40
3	Disc cover	Ductile iron GGG40
4	Disc sealing	Rubber EPDM
5	Upper stem	410 stainless steel
6	Lower stem	410 stainless steel
7	Disc pin	431 stainless steel
8	Disc nut	Bronze
9	Body cover	Ductile iron GGG40
10	Adjust cover	410 stainless steel
11	Protection cover	Ductile iron GGG40
12	Gland	Steel Q235-A
13	Stem cover	Steel Q235-A
14	Seat	304 stainless steel
15	V ring	EPDM
16	Upper bearing	Bronze filled PTFE or bronze with PTFE coating
17	Bearing	Bronze filled PTFE or bronze with PTFE coating
18	Adjust nut	420 stainless steel

Applicable standards:

- Design standard: EN 593.
- Flange connection standard: EN 1092-2.
- Face to face dimensions standard: EN 558-1 basic series 13.
- Top flange standard: ISO 5211/1.

Technical data:

- Size: DN 400 - DN 1200 (16" - 48").
- Nominal pressure: PN10.
- Temperature range: -5 °C to 65 °C.
- Suitable for water and neutral liquids.

Features and benefits:

- Manufactured with a double flat disc structure for increased strength and stiffness.
- Designed to offer optimal seal performance.
- Low torque operation.
- Disc O-ring manufactured from high quality EPDM rubber.
- Disc O-ring designed for easy replacement.
- Manufactured from quality ductile iron.
- Suitable for water and neutral liquids.
- Manufactured from high quality ductile iron.
- Electrostatically coated with corrosion resistant epoxy powder internally and externally.

Valve opening - flow coefficient curve diagram

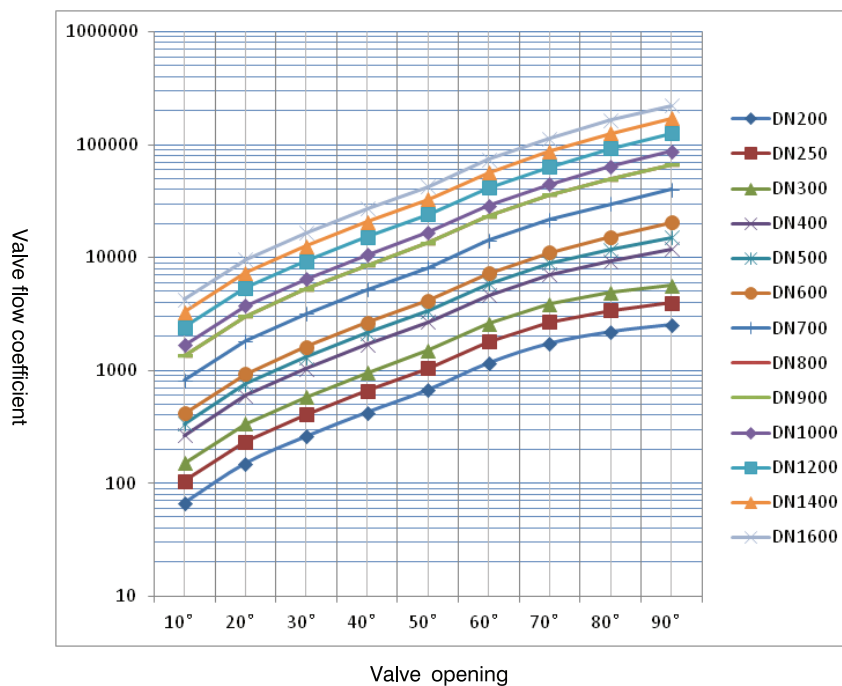

BFGX Flange Eccentric Butterfly Valve

Order code	Size	DN	L mm	H1 mm	H2 mm	H3 mm	H4 mm	D mm	D1 mm	D2 mm	D-d mm	Weight (kg)
B0350BFDTG13DO	14"	320	190	320	381	340	282	505	460	300	16-23	81.5
B0400BFDTG13DO	16"	400	216	350	401	360	282	565	515	300	16-28	103.4
B0450BFDTG13DO	18"	450	222	380	427	385	365	615	565	400	20-28	152.9
B0500BFDTG13DO	20"	500	229	410	466	425	365	670	620	400	20-28	181.3
B0600BFDTG13DO	24"	600	267	470	571	515	328	780	725	400	20-31	208.6
B0700BFDTG13DO	28"	700	292	535	615	560	467	895	840	400	24-31	293.5
B0800BFDTG13DO	32"	800	318	590	680	625	547	1015	950	400	24-34	589.3
B0900BFDTG13DO	36"	900	330	675	777	715	430	1115	1050	400	28-34	736.4
B1000BFDTG13DO	40"	1000	410	735	822	760	450	1230	1160	500	28-37	908.8
B1200BFDTG13DO	48"	1200	470	865	985	900	491	1455	1380	500	32-40	1516.5

BFGX PN16 product details and part no's available on request.

BWAX Wafer Concentric Butterfly Valve with Electric Modulating Actuator PN16

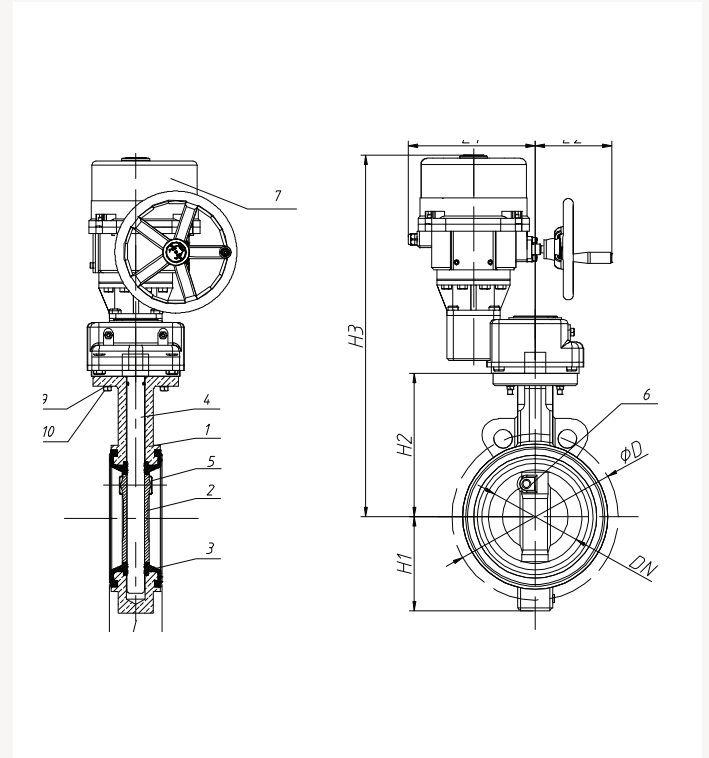

Note: This is a motorised version of the BW series butterfly valve. Modulating actuator.

Material specification

BWAX Wafer Concentric Butterfly Valve with Electric Modulating Actuator 2" to 24"

No	Component	Material
1	Body	Ductile iron GGG40
2	Disc	304 stainless steel
3	Seat	EPDM
4	Stem	410 stainless steel
5	Wedge pin	431 stainless steel
6	Screw pin	304 stainless steel
7	Actuator and gearbox	Manufactured by Rotork
8	Key	45 carbon steel
9	Washer	65 Mn steel
10	Bolt	Grade 8.8 carbon steel
11	O-ring	EPDM

Valve applicable standards:

- Design standard: EN 593, BS 5155.
- Connection standard: EN 1092-2.
- Face to face standard: EN 558-1 basic series 20.
- Top flange standard: ISO 5211-1.

Valve technical data:

- Size: DN 50 - DN 150 (2" - 6").
- Nominal pressure: PN16.
- Temperature range: -10 °C to 90 °C.
- Suitable for water and neutral liquids.

Valve features and benefits:

- Wafer pattern design, for quick installation.
- Replaceable EPDM seat suitable for variety of flange types.
- Streamlined stainless steel disc ensures lower water head loss.
- ISO compatible top flange enables easy actuator mounting.
- Bi directional shut off seat prevents backflow within the pipeline.
- Manufactured from high quality ductile iron.
- Electrostatically coated with corrosion resistant epoxy powder internally and externally.

Actuator technical data:

- Power supply voltage: 220V.
- Protection level: IP67.
- Working temperature: -5 °C to 70 °C.
- Working environment: No corrosive, flammable or explosive media.

Actuator features and benefits:

- Temperature overload protection.
- Switchable between manual and electric actuation.
- IP67 protection level.
- Modulating type actuator.

BWAX Concentric Butterfly Valve with Electric Modulating Actuator

Order code	Size	DN	L mm	H1 mm	H2 mm	H3 mm	øD1 mm	L1 mm	L2 mm	Power W	Switch time sec	Weight (kg)	Material code
B0050CWCNM20SO	2"	50	43	57	115	303	-	57	108	10	11	7.2	28101070004
B0065CWCNM20SO	2.1/2"	65	46	70	122	310	-	57	108	10	11	7.2	28101080004
B0080CWCNM20SO	3"	80	46	82	130	318	160	57	108	10	11	7.0	28101081004
B0100CWCNM20SO	4"	100	52	100	150	338	191	57	108	10	22	8.2	28101082004
B0125CWCNM20SO	5"	125	56	125	162	427	210	120	240	40	19	18.0	28101090004
B0150CWCNM20SO	6"	150	56	140	190	495	240	120	265	40	39	22.6	28101091004
B0200CWCNM20SO	8"	200	60	174	247	568	295	150	297	90	29	22.0	28101092004
B0250CWCNM20SO	10"	250	68	209	280	601	355	150	297	90	39	22.0	28101093004
B0300CWCNM20SO	12"	300	78	253	324	645	410	150	297	90	47	22.0	28101094004
B0350CWCNM20SO	14"	350	78	260	368	689	470	150	297	120	47	22.0	28101095004
B0400CWCNM20SO	16"	400	102	315	400	765	525	150	325	200	47	29.0	28101096008
B0450CWCNM20SO	18"	450	114	330	425	790	578	150	325	200	47	29.0	28101097008
B0500CWCNM20SO	20"	500	127	363	485	1017	635	302	182	200	76	76.0	28101098008
B0600CWCNM20SO	24"	600	154	440	565	1097	749	302	182	200	105	76.0	281010A0008

BWTX Wafer Concentric Butterfly Valve with Electric On/Off Actuator PN16

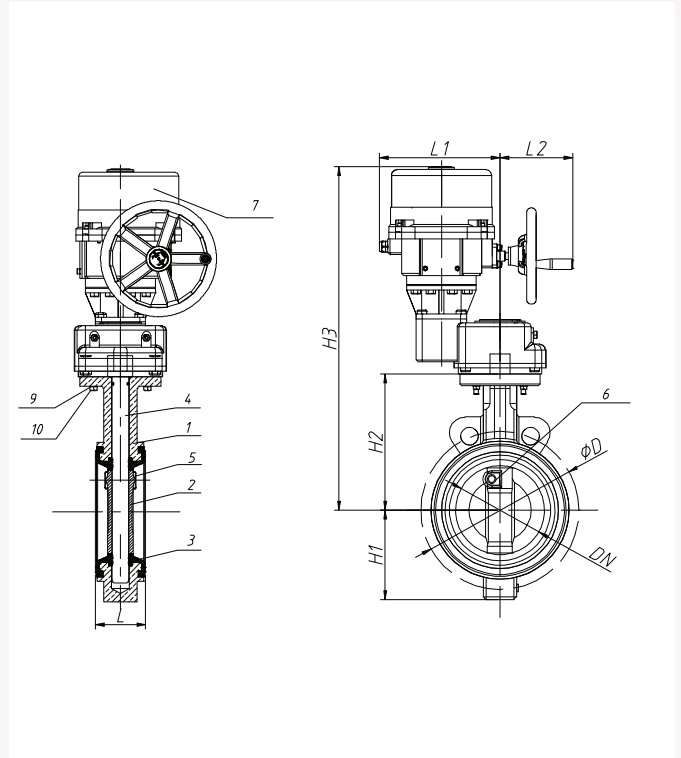

Note: This is a motorised version of the BW series butterfly valve. On off actuator.

Material specification

BWTX Wafer Concentric Butterfly Valve with Electric On/Off Actuator 2" to 24"

No	Component	Material
1	Body	Ductile iron GGG40
2	Disc	304 stainless steel
3	Seat	EPDM
4	Stem	410 stainless steel
5	Wedge pin	431 stainless steel
6	Screw pin	304 stainless steel
7	Actuator and gearbox	Manufactured by Rotork
8	Key	45 carbon steel
9	Washer	65 Mn steel
10	Bolt	Grade 8.8 carbon steel
11	O-ring	EPDM

Valve applicable standards:

- Design standard: EN 593, BS 5155.
- Connection standard: EN 1092-2.
- Face to face standard: EN 558-1. basic series 20.
- Top flange standard: ISO 5211-1.

Valve technical data:

- Size: DN 50 - DN 150 (2" - 6").
- Nominal pressure: PN16.
- Temperature range: -10 °C to 90 °C.
- Suitable for water and neutral liquids.

Valve features and benefits:

- Wafer pattern design, for quick installation.
- Replaceable EPDM seat suitable for variety of flange types.
- Streamlined stainless steel disc ensures lower water head loss.
- ISO compatible top flange enables easy actuator mounting.
- Bi directional shut off seat prevents backflow within the pipeline.
- Manufactured from high quality ductile iron.
- Electrostatically coated with corrosion resistant epoxy powder internally and externally.

Actuator technical data:

- Power supply voltage: 220V.
- Protection level: IP67.
- Working temperature: -5 °C to 70 °C.
- Working environment: No corrosive, flammable or explosive media.

Actuator feature and benefits:

- Temperature overload protection.
- Switchable between manual and electric actuation.
- IP67 protection level.
- On/off type actuator.

BWTX Wafer Concentric Butterfly Valve with Electric On/Off Actuator

Order code	Size	DN	L mm	H1 mm	H2 mm	H3 mm	øD1 mm	L1 mm	L2 mm	Power W	Switch time sec	Weight (kg)
B0050CWCNE20SO	2"	50	43	57	115	303	-	57	108	10	11	7.2
B0065CWCNE20SO	2.1/2"	65	46	70	122	310	-	57	108	10	11	7.2
B0080CWCNE20SO	3"	80	46	82	130	318	160	57	108	10	11	7.0
B0100CWCNE20SO	4"	100	52	100	150	338	191	57	108	10	22	8.2
B0125CWCNE20SO	5"	125	56	125	162	427	210	120	240	40	19	18.0
B0150CWCNE20SO	6"	150	56	140	190	495	240	120	265	40	39	22.6
B0200CWCNE20SO	8"	200	60	174	247	568	295	150	297	90	29	22.0
B0250CWCNE20SO	10"	250	68	209	280	601	355	150	297	90	39	22.0
B0300CWCNE20SO	12"	300	78	253	324	645	410	150	297	90	47	22.0
B0350CWCNE20SO	14"	350	78	260	368	689	470	150	297	120	47	22.0
B0400CWCNE20SO	16"	400	102	315	400	765	525	150	325	200	47	29.0
B0450CWCNE20SO	18"	450	114	330	425	790	578	150	325	200	47	29.0
B0500CWCNE20SO	20"	500	127	363	485	1017	635	302	182	200	76	76.0
B0600CWCNE20SO	24"	600	154	440	565	1097	749	302	182	200	105	76.0

3.0 Check Valves

Conex Bänninger offers a wide range of brass, DZR brass, bronze and ductile iron check valves. Check valves work automatically to keep water flowing in one direction and prevent any reverse flow in the system.

Double check valves

Conex Bänninger Double Check Valves consist of two check valve assemblies in series. This employs two operating principles; firstly, one check valve will still act, even if the other is obstructed; secondly, the closure of one valve reduces the pressure differential across the other, allowing a more reliable seal and avoiding even minor leakage. Double check valves are designed specifically to prevent contamination in drinking water systems. These valves are designed in accordance with EN 13959: 2004 Family E, type D.

Horizontal lift check valves

Conex Bänninger Horizontal Lift Check Valves are suitable for installation in horizontal or vertical pipelines with upward flow. Flow to lift check valves must always enter below the seat. Lift check valves are particularly suitable for high pressure service where velocity of flow is high or in conditions where pulsating action in the line may cause excessive wear in swing check type valves. This type of check valve is commonly used in piping systems, in which globe valves are used as flow control valves.

Spring check non-return valves

Spring check non-return valves are simple, low cost but effective products providing back flow protection. Conex Bänninger Spring Check Valves are manufactured from high quality brass.

Foot valves

Foot valve assemblies comprise a spring check non-return valve fitted with a strainer screen on the inlet side. These products are most often used in connection with drawing fluid from a well, tank or reservoir. The screen prevents soil, dirt and debris getting in the system, thus protecting the valves further along the pipeline.

Swing check valves

Swing check valves are used for water and other liquids. Swing check valves can be installed in horizontal or vertical upward flow pipe systems.

Flex swing check valves

The valve is of the swing check type utilizing an 15° angled seat with an unrestricted flow area for improved flow characteristics and low head loss. The valves are manufactured from high quality ductile iron coated with epoxy powder. The disc is fully encapsulated in vulcanised EPDM rubber to protect against corrosion. The valve is suitable for applications utilising water.

Dual plate check valves

Dual plate check valves are all purpose non-return valves that are lighter, smaller and stronger than traditional counterparts such as swing check valves. The spring loaded plates provide a quick, non slam closure without requiring reverse slow and preventing water hammer. Conex Bänninger Dual Plate Check Valves are available with a high temperature vulcanised sealing ring and can be installed in a horizontal or vertical position.

Spring loaded silent check valves

The Conex Bänninger Spring Loaded Silent Check Valve is designed to minimise water hammer and noise by utilising an axially mounted spring assisted disc which closes positively and silently before a reversal of fluid flow takes place. A spring loaded silent check valve will completely close while there is still a positive head on the inlet side. Spring loaded silent check valves can be configured in a vertical or horizontal position and feature a resilient seat for zero leakage.

Backflow preventers

The Conex Bänninger CVBP series of ductile iron backflow preventers consists of two check valves and an automatic drain valve and is used to prohibit cross contamination (backflow) from the branch or terminal pipeline network to the main pipeline. For example separate drinking water from AC water, fire fighting water or irrigation water. Conex Bänninger CVBP Backflow Preventers have a streamlined inner design to minimise pressure drop. Quick close functionality avoids pipeline damage from water hammer. The integrated external drain valve enables easy maintenance and its tamperproof function avoids accidental drainage.



1340 Double Check Valve PN16 - (DZR)

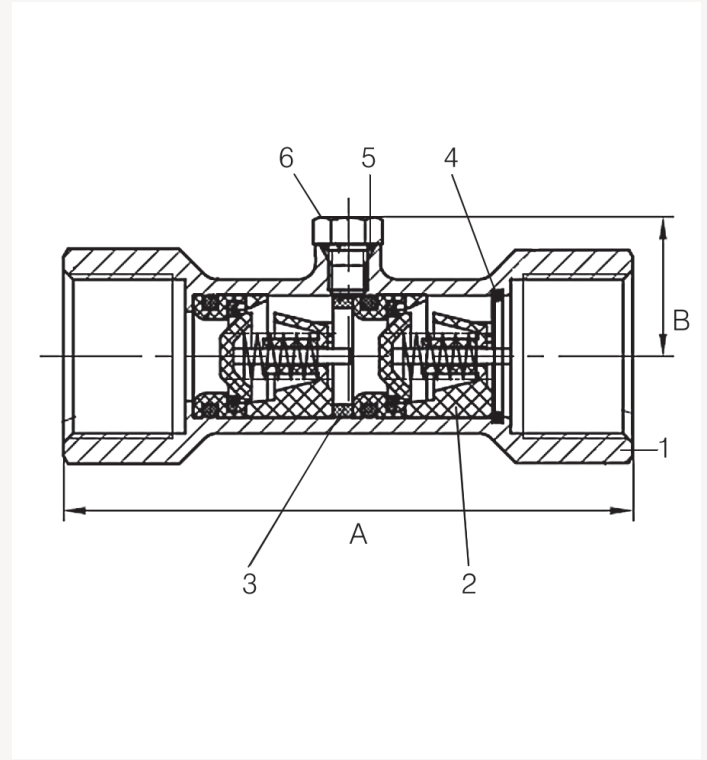

Material specification

1340 Double Check Valve 1/2" to 2"			
No	Component	Material	Specification
1	Body	DZR brass	EN 12165 CW602N
2	Check spool	Acetal	Acetal
3	Retaining ring	Nylon	Nylon 66
4	Clip	Stainless steel	ISO 15510
5	O-ring	EPDM	EN 2430: 1995
6	Inspection port	DZR brass	EN 12164 CW602N

Features and benefits:

- Designed in accordance with EN 13959, family E, type D.
- WRAS approved for drinking water applications.
- End connections, ISO 228 parallel threads, female ends.
- PN16 from -10° to +85 °C.
- Suitable for low temperature hot water and chilled systems.
- Prevents backflow.
- Drain screw / inspection port.

1340 Double Check Valve

Order code ISO 228	Size	DN	A	B	Kv value	Weight (kg)
134050FF0160404	1/2"	15	70	17	2.7	0.10
134050FF0160606	3/4"	20	85	20	4.8	0.17
134050FF0160808	1"	25	100	23	10	0.27
134050FF0161010	1.1/4"	32	120	26	19.6	1.40
134050FF0161212	1.1/2"	40	138	30	35.5	1.58
134050FF0161616*	2"	50	183	36	-	1.30

* Valve available to special order.

Valve suitability

Product	Steam	Water	Drinking water	Oil	Air (oil free)	Gas (inert)	Gas (combustible)	Gas (corrosive)	Gas (oxygen)
1340	x	✓	✓	x	x	x	x	x	x

Max. working parameters

1340	Temperature °C	Pressure bar	Pressure psi
Water	-10 to +85	16	230

Specification clauses:

- Designed in accordance with EN 13959.
- WRAS approved for drinking water applications.
- Suitable for low temperature hot water and chilled systems.
- Prevents backflow.
- End connections, ISO 228 parallel threads, female ends.
- Inspection port.

1360 Horizontal Lift Check Valve PN32 - (bronze)

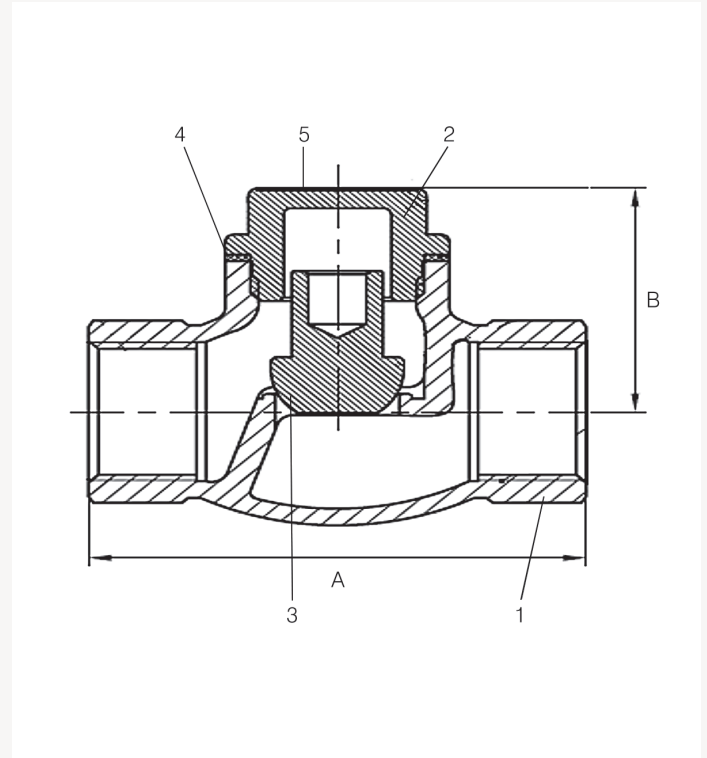

Material specification

1360 Horizontal Lift Check Valve 1/2" to 2"			
No	Component	Material	Specification
1	Body	Bronze	EN 1982 CC491K
2	Cap	Bronze	EN 1982 CC491K
3	Disc	Bronze	EN 1982 CC491K
4	Gasket seal	PTFE	PTFE
5	ID disc	Aluminium	EN 1706 LM6

Features and benefits:

- Designed in accordance with EN 5154.
- Suitable for water, oil and oil free air applications.
- Suitable for low temperature hot water and chilled systems.
- WRAS approved for drinking water applications.
- Metal to metal seat.
- Seating disc guided inside cap.
- End connections, female taper threads to EN 10226-2 (ISO 7-1) and parallel threads to ISO 228.

1360 Horizontal Lift Check Valve

Order code EN 10226-2 (ISO 7-1) thread	Order code ISO 228 thread	Size	DN	A	B	Kv value	Weight (kg)
136020RR0320404	136020FF0320404	1/2"	15	60	34	-	0.28
136020RR0320606	136020FF0320606	3/4"	20	75	42	-	0.44
136020RR0320808	136020FF0320808	1"	25	85	46	12.3	0.60
136020RR0321010	136020FF0321010	1.1/4"	32	100	51	-	1.14
136020RR0321212	136020FF0321212	1.1/2"	40	110	54	-	1.46
136020RR0321616	136020FF0321616	2"	50	120	72	-	2.57

Valve suitability

Product	Steam	Water	Drinking water	Oil	Air (oil free)	Gas (inert)	Gas (combustible)	Gas (corrosive)	Gas (oxygen)
1360	x	✓	✓	✓	✓	x	x	x	x

This valve is not suitable for gas applications.

Max. working parameters

1360	Temperature °C	Pressure bar	Pressure psi
Water	-10 to +100	32	460

Specification clauses:

- Valves are designed in accordance with EN 5154.
- WRAS approved for drinking water applications.
- Suitable for low temperature hot water and chilled systems.
- Disc is spherical shaped, guided in the cap.
- Body seat is integral.
- End connections, female taper threads to EN 10226-2 (ISO 7-1) and parallel threads to ISO 228.

1451 Spring Check Non Return Valve PN10/PN12 - (brass)

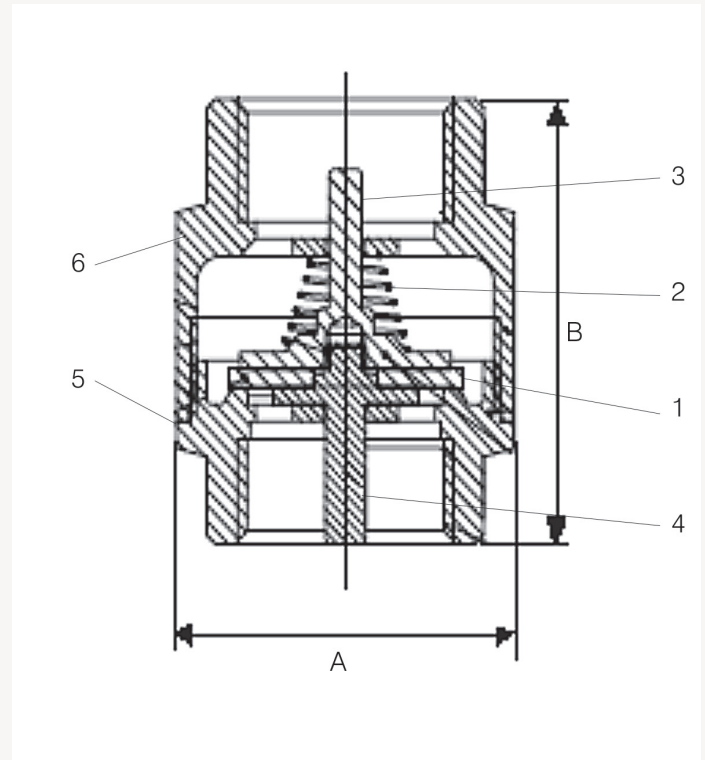

Material specification

1451 Spring Check Non Return Valve 1/2" to 2"			
No	Component	Material	Specification
1	Seat	EPDM	EN 2430: 1995
2	Spring	Stainless steel	ISO 15510
3	Spindle core (upstream)	Brass	EN 12165 CW617N-DW
4	Spindle core (downstream)	Brass	EN 12165 CW617N-DW
5	Bonnet	Brass	EN 12165 CW617N-DW
6	Body	Brass	EN 12165 CW617N-DW

Features and benefits:

- WRAS approved for drinking water applications.
- Brass core for improved strength and performance.
- PN12 up to 1", PN10 above 1".
- End connections, female parallel threads to ISO 228 female ends.
- Suitable for low temperature hot water systems.

1451 Spring Check Non Return Valve

Order code ISO 228 thread	Size	DN	A	B	Kv value	Weight (kg)
145110FF0120404	1/2"	15	65	33	2.4	0.14
145110FF0120606	3/4"	20	86	42	3.3	0.24
145110FF0120808	1"	25	103	47	-	0.27
145110FF0101010	1.1/4"	32	119	59	17.2	0.52
145110FF0101212	1.1/2"	40	141	67	36.5	0.74
145110FF0101616	2"	50	159	83	52.7	1.06

Valve suitability

Product	Steam	Water	Drinking water	Oil	Air (oil free)*	Gas (inert)	Gas (combustible)	Gas (corrosive)	Gas (oxygen)
1451	x	✓	x	✓	✓	x	x	x	x

* Limited to 5 bar max.

Max. working parameters

1451	Size	Temperature °C	Pressure bar	Pressure psi	Min. operating pressure bar
Water	1/2" - 1"	-10 to +100	12	174	-0.002 to +0.04
Water	1.1/4" - 2"	-10 to +100	10	145	-0.002 to +0.04

Not suitable for temperatures above +100 °C.

Specification clauses:

- WRAS approved for drinking water applications.
- Suitable for low temperature hot water systems.
- End connections, female parallel threads to ISO 228 female ends.
- Brass core for improved strength and performance.

1461 Foot Valve PN10/PN12 - (brass)

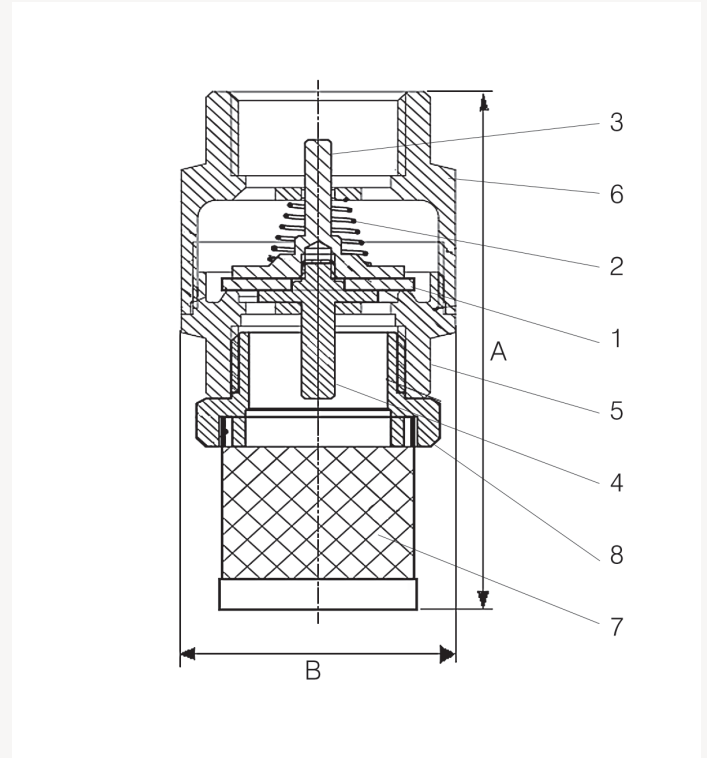

Material specification

1461 Foot Valve 1/2" to 2"			
No	Component	Material	Specification
1	Seat	EPDM	EN 2430: 1995
2	Spring	Stainless steel	ISO 15510
3	Spindle core (upstream)	Brass	EN 12165 CW617N-DW
4	Spindle core (downstream)	Brass	EN 12165 CW617N-DW
5	Bonnet	Brass	EN 12165 CW617N-DW
6	Body	Brass	EN 12165 CW617N-DW
7	Strainer	Stainless steel	ISO 15510
8	Strainer adaptor	Acetal	Acetal

Features and benefits:

- Designed in accordance with WRAS requirements.
- Stainless steel mesh strainer.
- Brass core for improved strength and performance.
- PN12 up to 1", PN10 above 1".
- End connections, parallel threads to ISO 228 female ends.
- Suitable for low temperature hot water systems.

1461 Foot Valve						
Order code ISO 228 thread	Size	DN	A	B	Kv value	Weight (kg)
146110FF0120404	1/2"	15	65	33	2.4	0.14
146110FF0120606	3/4"	20	86	42	3.3	0.24
146110FF0120808	1"	25	103	47	-	0.27
146110FF0101010	1.1/4"	32	119	59	17.2	0.52
146110FF0101212	1.1/2"	40	141	67	36.5	0.74
146110FF0101616	2"	50	159	83	52.7	1.06

Valve suitability

Product	Steam	Water	Drinking water	Oil	Air (oil free)	Gas (inert)	Gas (combustible)	Gas (corrosive)	Gas (oxygen)
1461	x	✓	x	✓	✓	x	x	x	x

* Limited to 5 bar max.

Max. working parameters

1461	Size	Temperature °C	Pressure bar	Pressure psi	Min. operating pressure bar
Water	1/2" - 1"	-10 to +100	12	174	-0.002 to +0.04
Water	1.1/4" - 2"	-10 to +100	10	145	-0.002 to +0.04

Not suitable for temperatures above +100 °C.

Specification clauses:

- Suitable for low temperature hot water systems.
- End connections, parallel threads to ISO 228 female ends.
- Brass core for improved strength and performance.
- Stainless steel mesh strainer.

1470 Swing Check Valve PN25 - (brass)

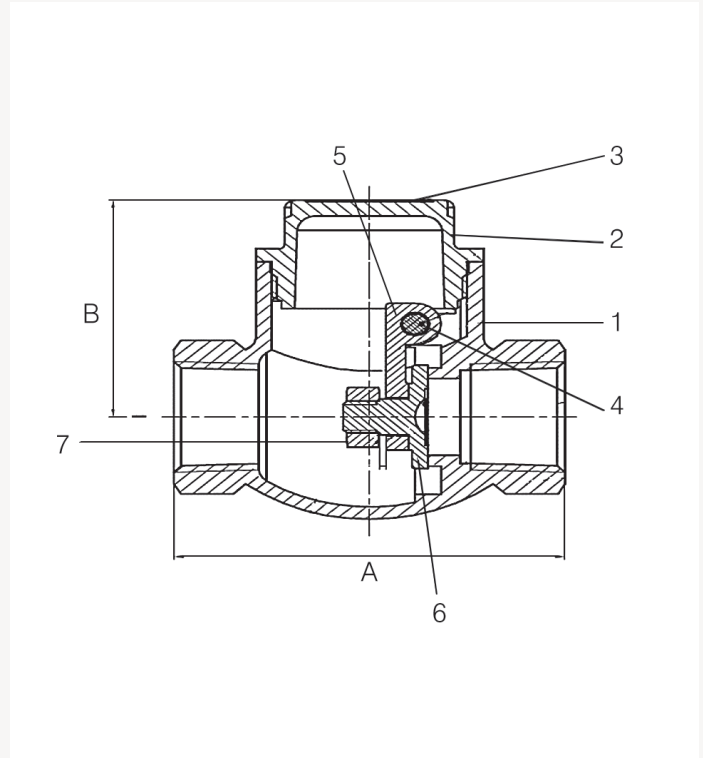

Material specification

1470 Swing Check Valve 1/2" to 2"			
No	Component	Material	Specification
1	Body	Brass	EN 12165 CW617N-DW
2	Cap	Brass	EN 12165 CW617N-DW
3	Identity disc	Aluminium	EN 1706 LM6
4	Swing pin	Stainless steel	ISO 15510
5	Swing arm	Brass	EN 12165 CW617N-DW
6	Seat	Brass	EN 12165 CW617N-DW
7	Retaining nut	Brass	EN 12165 CW617N-DW

Features and benefits:

- WRAS approved for drinking water systems.
- Suitable for water and other liquids.
- Metal to metal seat.
- Horizontal swing check design.
- Choice of alternative disc material to special order.
- End connections, female taper threads to EN 10226-2 (ISO 7-1) and parallel threads to ISO 228.
- Suitable for low temperature hot water systems.

1470 Swing Check Valve

Order code EN 10226-2 (ISO 7-1) thread	Order code ISO 228 thread	Size	DN	A	B	Kv value	Weight (kg)
147010RR0250404	147010FF0250404	1/2"	15	60	42	5.8	0.26
147010RR0250606	147010FF0250606	3/4"	20	70	48	7.1	0.37
147010RR0250808	147010FF0250808	1"	25	80	54	23	0.64
147010RR0251010	147010FF0251010	1.1/4"	32	90	60	-	0.92
147010RR0251212	147010FF0251212	1.1/2"	40	100	70	82	1.26
147010RR0251616	147010FF0251616	2"	50	110	80	93	1.95

Valve suitability

Product	Steam	Water	Drinking water	Oil	Air (oil free)	Gas (inert)	Gas (combustible)	Gas (corrosive)	Gas (oxygen)
1470	x	✓	✓	✓	✓	x	x	x	x

This valve is not suitable for gas applications.

Max. working parameters

1470	Temperature °C	Pressure bar	Pressure psi
Water	-10 to +100	25	360

Specification clauses:

- Brass body.
- Metal disc, screwed in cap.
- Operation is automatic using a swing type check.
- Valves are manufactured in accordance with EN 5154:1991 PN25 for Series B ratings.
- End connections, female taper threads to EN 10226-2 (ISO 7-1) and parallel threads to ISO 228.
- WRAS approved for drinking water systems.
- Suitable for low temperature hot water systems.

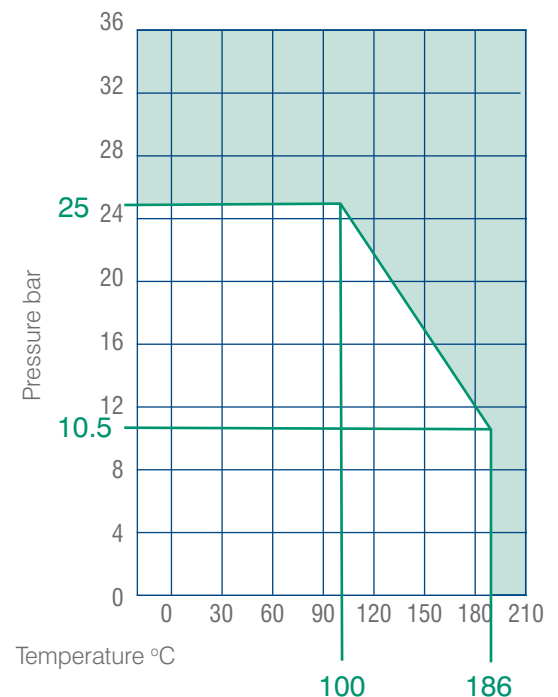

1470 Swing Check Valve PN25 - (bronze)

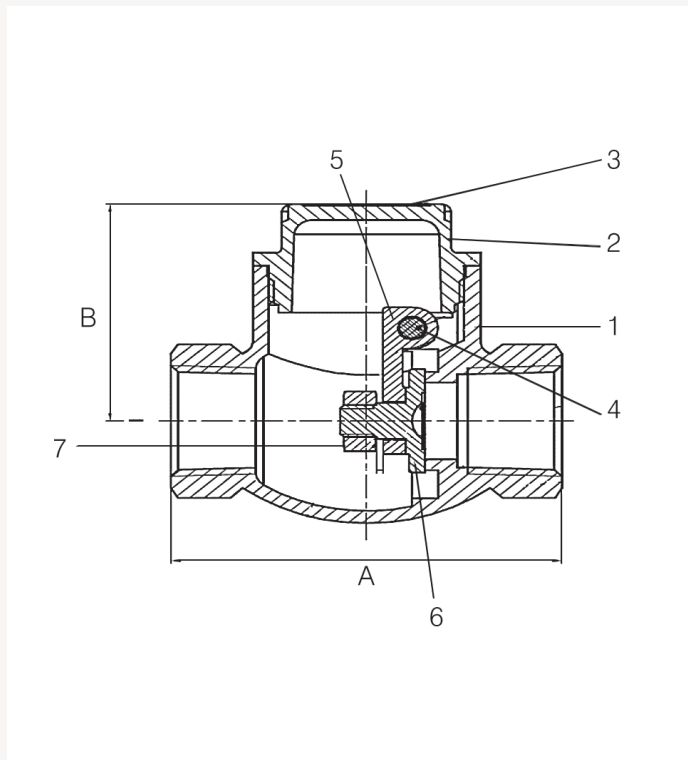

Material specification

1470 Swing Check Valve 1/2" to 2"

No	Component	Material	Specification
1	Body	Bronze	EN 1982 CC491K
2	Cap	Bronze	EN 1982 CC491K
3	Identity disc	Aluminium	EN 1706 LM6
4	Swing pin	Stainless steel	ISO 15510
5	Swing arm	Bronze	EN 1982 CC491K
6	Seat	Bronze	EN 1982 CC491K
7	Retaining nut	Bronze	EN 1982 CC491K

Features and benefits:

- WRAS approved for drinking water systems.
- Horizontal swing check design.
- Metal to metal seat.
- Choice of alternative disc material to special order.
- End connections, female taper threads to EN 10226-2 (ISO 7-1) and parallel threads to ISO 228.
- Suitable for water and other liquids.
- Suitable for low temperature hot water and chilled systems.

1470 Swing Check Valve

Order code EN 10226-2 (ISO 7-1) thread	Order code ISO 228 thread	Size	DN	A	B	Kv value	Weight (kg)
147020RR0250404	147020FF0250404	1/2"	15	60	42	5.8	0.36
147020RR0250606	147020FF0250606	3/4"	20	70	48	7.1	0.44
147020RR0250808	147020FF0250808	1"	25	80	54	23	0.69
147020RR0251010	147020FF0251010	1.1/4"	32	90	60	-	0.97
147020RR0251212	147020FF0251212	1.1/2"	40	100	70	82	1.38
147020RR0251616	147020FF0251616	2"	50	110	80	93	2.01

Valve suitability

Product	Steam	Water	Drinking water	Oil	Air (oil free)	Gas (inert)	Gas (combustible)	Gas (corrosive)	Gas (oxygen)
1470	x	✓	✓	✓	✓	x	x	x	x

This valve is not suitable for gas applications.

Max. working parameters

1470	Temperature °C	Pressure bar	Pressure psi
Water	-10 to +100	25	360

Specification clauses:

- Valves are manufactured in accordance with EN 5154:1991 PN25 for Series B ratings.
- Bronze body.
- Metal disc, screwed in cap.
- Operation is automatic using a swing type check.
- End connections, female taper threads to EN 10226-2 (ISO 7-1) and parallel threads to ISO 228.
- WRAS approved for drinking water systems.
- Suitable for low temperature hot water and chilled systems.

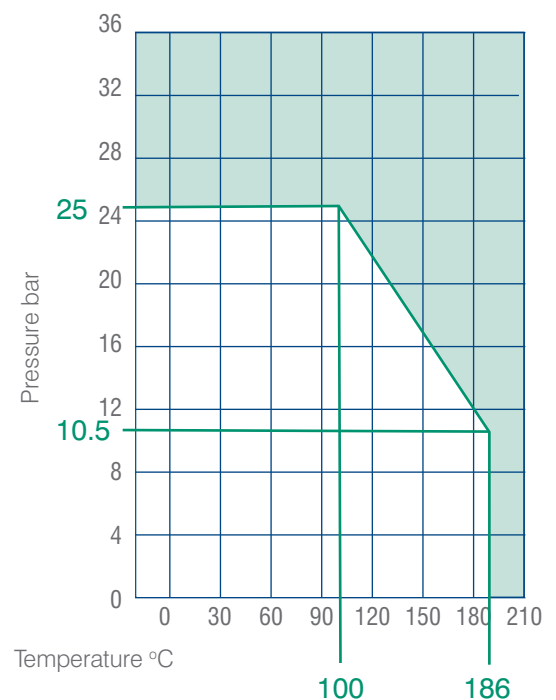

CVSF Flex Swing Check Valve PN16 flanged

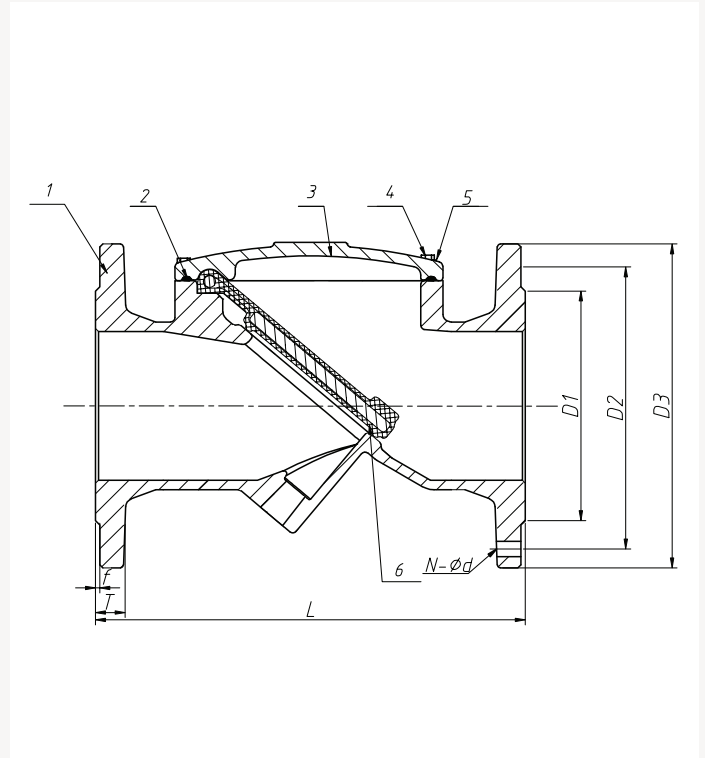

Material specification

CVSF Flex Swing Check Valve 2" to 16"

No	Component	Material
1	Body	Ductile iron GGG40
2	Gasket	Rubber EPDM
3	Cover	Ductile iron GGG40
4	Bolt	Carbon steel + zinc coating grade 8.8
5	Washer	Carbon steel+ zinc coating
6	Disc	Carbon steel fully vulcanised EPDM

Applicable standards:

- Connection standard: EN 1092-2.
- Pressure test standard: EN 12266.
- Face to face standard: EN 558.

Technical data:

- Size: DN 50 - DN 300 (2" - 16").
- Nominal pressure: PN16.
- Temperature range: -5 °C to 85 °C.
- Suitable for water.

Features and benefits:

- 15° sealing angle to ensure low pressure shut-off.
- Suitable for water applications.
- Manufactured from high quality ductile iron.
- Unrestricted flow area for improved flow characteristics and low head loss.
- Designed with an integral EPDM gasket for low and high pressure installation.
- Electrostatically coated with corrosion resistant epoxy powder internally and externally.

CVSF Flex Swing Check Valve

Order code	Size	DN	D1 mm	D2 mm	D3 mm	n-ød mm	L mm	T mm	f mm	Weight (kg)
C0050CFDMN10DO	2"	50	99	125	165	4-ø19	203	19	3.0	9
C0065CFDMN10DO	2.1/2"	65	118	145	185	4-ø19	216	19	3.0	11
C0080CFDMN10DO	3"	80	132	160	200	8-ø19	241	19	3.0	13
C0100CFDMN10DO	4"	100	156	180	220	8-ø19	292	19	3.0	18
C0125CFDMN10DO	5"	125	184	210	250	8-ø19	330	19	3.0	26
C0150CFDMN10DO	6"	150	211	240	285	8-ø23	356	19	3.0	33
C0200CFDMN10DO	8"	200	266	295	340	12-ø23	495	20	3.0	62
C0250CFDMN10DO	10"	250	319	355	405	12-ø28	622	22	3.0	93
C0300CFDMN10DO	12"	300	370	410	460	12-ø28	698	25	4.0	143
C0350CFDMN10DO	14"	350	429	470	520	16-ø28	787	27	4.0	197
C0400CFDMN10DO	16"	400	480	525	580	16-ø31	914	28	4.0	271

* Available in PN10, please contact our sales team for further details.

CVDD Dual Plate Check Valve PN16 flanged

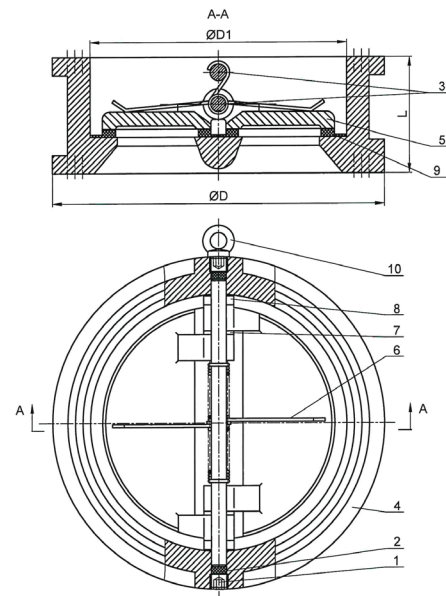

Drawing details representative of DN 50 to DN 300 valve construction. For details of valve construction for sizes DN350 to DN 600 please contact your local Conex Bänninger representative.

Material specification

CVDD Dual Plate Check Valve Flanged 2" to 24"

No	Component	Material
1	Screw	Carbon steel
2	Sealing ring	EPDM
3	Shaft	Stainless steel SS316
4	Body	Ductile iron
5	Disc	CF8/DI*/CF8M*/C95400*
6	Spring	Stainless steel SS316
7	Gasket	PTFE
8	Gasket	PTFE
9	Seat	EPDM
10	Lifting ring (for 8" and above)	Carbon steel

*Variants available to special order. Please contact your local Conex Bänninger representative.

Material details representative of DN 50 to DN 300 valve construction. For details of valve construction for sizes DN350 to DN 600 please contact your local Conex Bänninger representative

Applicable standards:

- Connection standard: EN 1092-2.
- Pressure test standard: EN 12266.
- Face to face standard: EN 558.

Technical data:

- Size: DN 50 – DN 600 (2" - 24").
- Nominal pressure: PN16.
- Shell test pressure: 24 bar.
- Seal test pressure: 17.6 bar.
- Temperature range: -20 °C to 110 °C.
- Suitable for water.

Features and benefits:

- Suitable for horizontal and vertical installation.
- Suitable for water applications.
- Available in sizes 2 - 24"
- Manufactured from high quality ductile iron.
- Designed and manufactured in accordance with EN 1092-2.

CVDD Dual Plate Check Valve Flanged 2" to 24"

Order Code	Size	DN	L	Ød1	Ød
C0050CWCMN16SO	2"	50	43	65	103
C0065CWCMN16SO	2 1/2"	65	46	80	123
C0080CWCMN16SO	3"	80	64	94	142
C0100CWCMN16SO	4"	100	64	117	157
C0125CWCMN16SO	5"	125	70	145	192
C0150CWCMN16SO	6"	150	76	170	218
C0200CWCMN16SO	8"	200	89	224	268
C0250CWCMN16SO	10"	250	114	265	328
C0300CWCMN16SO	12"	300	114	310	380
C0350CWCMN16SO	14"	350	127	360	439
C0400CWCMN16SO	16"	400	140	410	490
C0450CWCMN16SO	18"	450	152	450	554
C0500CWCMN16SO	20"	500	152	505	616
C0600CWCMN16SO	24"	600	178	624	724

Variants with DI/CF8M/C94500 disc available to special order. Please contact your local Conex Bänninger representative.

BRVB Spring Loaded Check Valve PN16 flanged

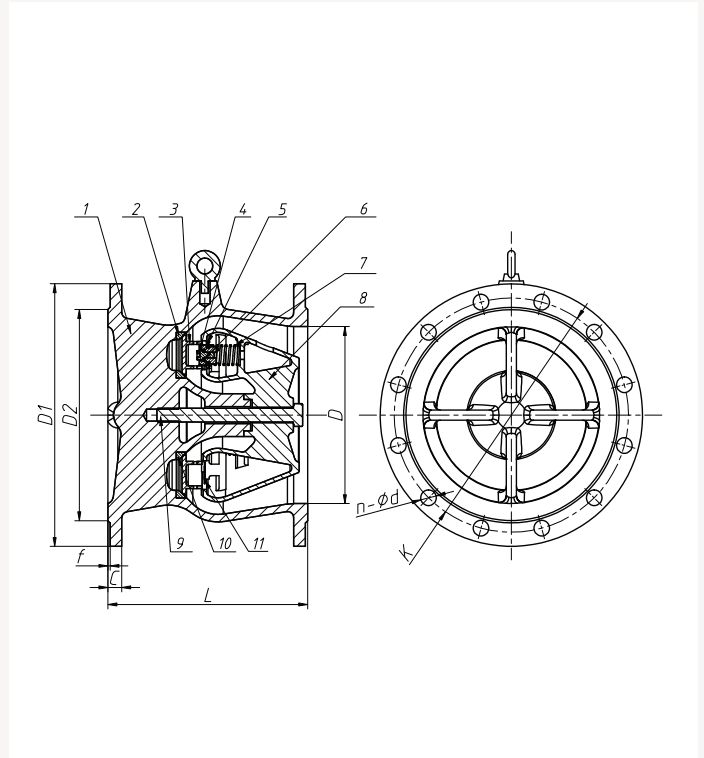

Material specification

BRVB Spring Loaded Check Valve 2" to 36"

No	Component	Material
1	Body	Ductile iron GGG40
2	Seat	410 stainless steel
3	Disc	410 stainless steel
4	Screw	Stainless steel
5	Pin	Stainless steel
6	Plate	Stainless steel
7	Spring	304 stainless steel
8	V-Body	Ductile iron GGG40
9	Srew	Stainless steel
10	Seat	410 stainless steel
11	Spring	304 stainless steel

Applicable standards:

- Connection standard: EN 1092-2.
- Pressure test standard: EN 12266.
- Face to face standard: EN 558.

Technical data:

- Size: DN 50 - DN 900 (2" - 36").
- Nominal pressure: PN16.
- Temperature range: -5 °C to 85 °C.
- Suitable for water.

Features and benefits:

- The spring loaded design reduces water hammer and noise.
- Axial flow design insures short stroke and quick closure.
- Can be installed in any position, including vertical with flow up or down.
- Resilient seated sealing, zero leakage.
- Electrostatically coated with corrosion resistant epoxy powder internally and externally.

BRVB Spring Loaded Check Valve

Order code	Size	DN	D1	D2	C mm	L mm	n-ød mm	K mm	f mm	Weight (kg)
C0050CFDMN01SO	2"	50	165	99	19	120	4-ø19	125	3	6.5
C0065CFDMN01SO	2.1/2"	65	185	118	19	140	4-ø19	145	3	8.9
C0080CFDMN01SO	3"	80	200	132	19	170	4-ø19	160	3	11.0
C0100CFDMN01SO	4"	100	235	156	19	180	4-ø19	190	3	13.8
C0125CFDMN01SO	5"	125	270	184	19	200	4-ø19	220	3	19.4
C0150CFDMN01SO	6"	150	300	211	20	250	4-ø19	250	3	19.4
C0200CFDMN01SO	8"	200	360	274	22	300	4-ø19	310	3	26.8
C0250CFDMN01SO	10"	250	425	330	25	350	4-ø19	370	3	44.1
C0300CFDMN01SO	12"	300	460	370	25	350	12-ø28	410	4	103.8
C0350CFDMN01SO	14"	350	520	429	27	405	16-ø28	470	4	154.5
C0400CFDMN01SO	16"	400	580	480	28	455	16-ø31	525	4	203.1
C0450CFDMN01SO	18"	450	640	548	30	520	20-ø31	585	4	274.2
C0500CFDMN01SO	20"	500	715	609	33	570	20-ø34	650	4	380.6
C0600CFDMN01SO	24"	600	840	720	36	685	20-ø37	770	5	605.5
C0700CFDMN01SO	28"	700	910	794	40	800	24-ø37	840	5	820.8
C0800CFDMN01SO	32"	800	1025	901	43	910	24-ø40	950	5	1185.6
C0900CFDMN01SO	36"	900	1125	1001	47	1030	28-ø40	1050	5	1346.5

CVBP Backflow Preventers PN10 / PN16 flanged

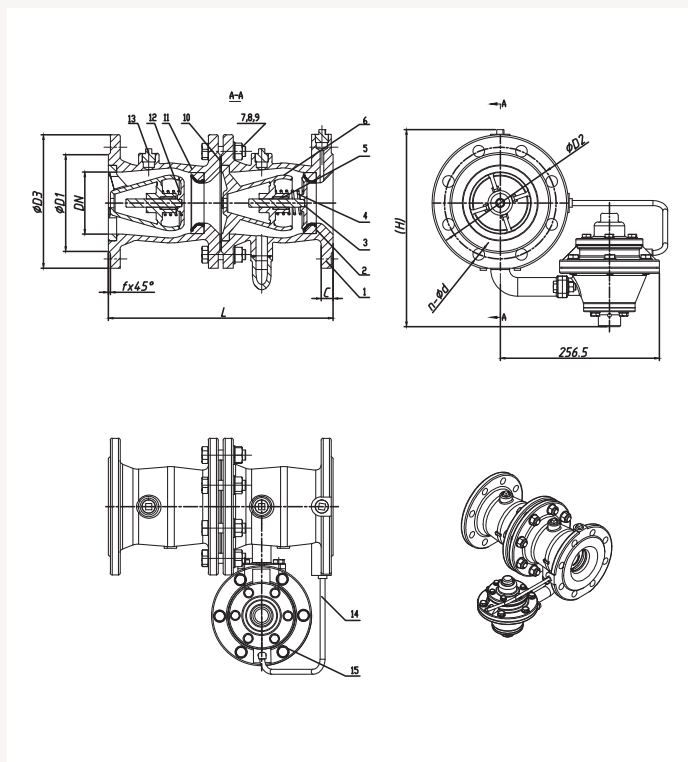

Material specification

CVBP Backflow Preventers 2 1/2" to 10"

No	Component	Material
1	Body	Ductile iron GGG40
2	Seat	420 stainless steel + rubber NBR
3	Disc	304 stainless steel
4	Spring	304 stainless steel
5	Bushing	Brass CW617
6	Deflector	Ductile iron GGG40
7	Bolt	Zinc coated steel
8	Nut	Zinc coated steel
9	Washer	Zinc coated steel
10	Washer	Rubber NBR
11	Body	Ductile iron GGG40
12	Spring	304 stainless steel
13	1/2 ball valve	Composite member
14	Flexible metal tubing	Composite member
15	Water drain valve	Composite member

Applicable standards:

- Manufacturer standard: GB / T25178.
- Flange standard: GB / T17241.6.
- Performance standard: GB / T25178.

Technical data:

- Nominal diameter: DN 50 - DN 250 (2" - 10").
- Nominal pressure: PN10 / PN16.
- Working temperature: 0 °C to 85 °C.
- Suitable for water.

Features and benefits:

- Axial flow, streamlined inner design, low pressure drop.
- Quick close design, avoids pipeline damage from water hammer.
- Integrated external drain valve enables easy maintenance.
- The drain valve is tamperproofed to avoid accidental drainage.
- Electrostatically coated with corrosion resistant epoxy powder internally and externally.

CVBP Backflow Preventers

Order code	Size	DN	D1	D2	D3 mm	f mm	C mm	n-ød mm	L mm	H mm	Weight (kg)
C0065CFDKNMSSO	2.1/2"	65	118	145	185	3	19	4-ø19	282	280	8.9
C0080CFDKNMSSO	3"	80	132	160	200	3	19	8-ø19	342	295	11.0
C0100CFDKNMSSO	4"	100	156	180	220	3	19	8-ø19	362	320	13.8
C0125CFDKNMSSO	5"	125	184	210	250	3	19	8-ø19	402	350	19.4
C0150CFDKNMSSO	6"	150	211	240	285	3	19	8-ø19	502	375	19.4
C0200CFDKNMSSO	8"	200	266	295	340	3	20	12-ø23	602	430	26.8
C0250CFDKNMSSO	10"	250	319	355	405	3	22	12-ø28	702	490	44.1

Performance curve

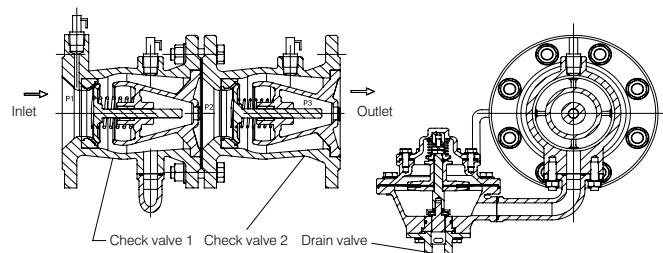
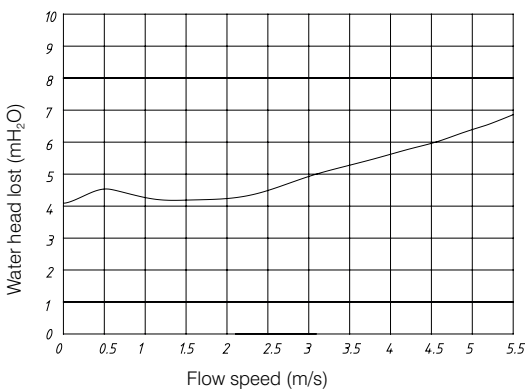

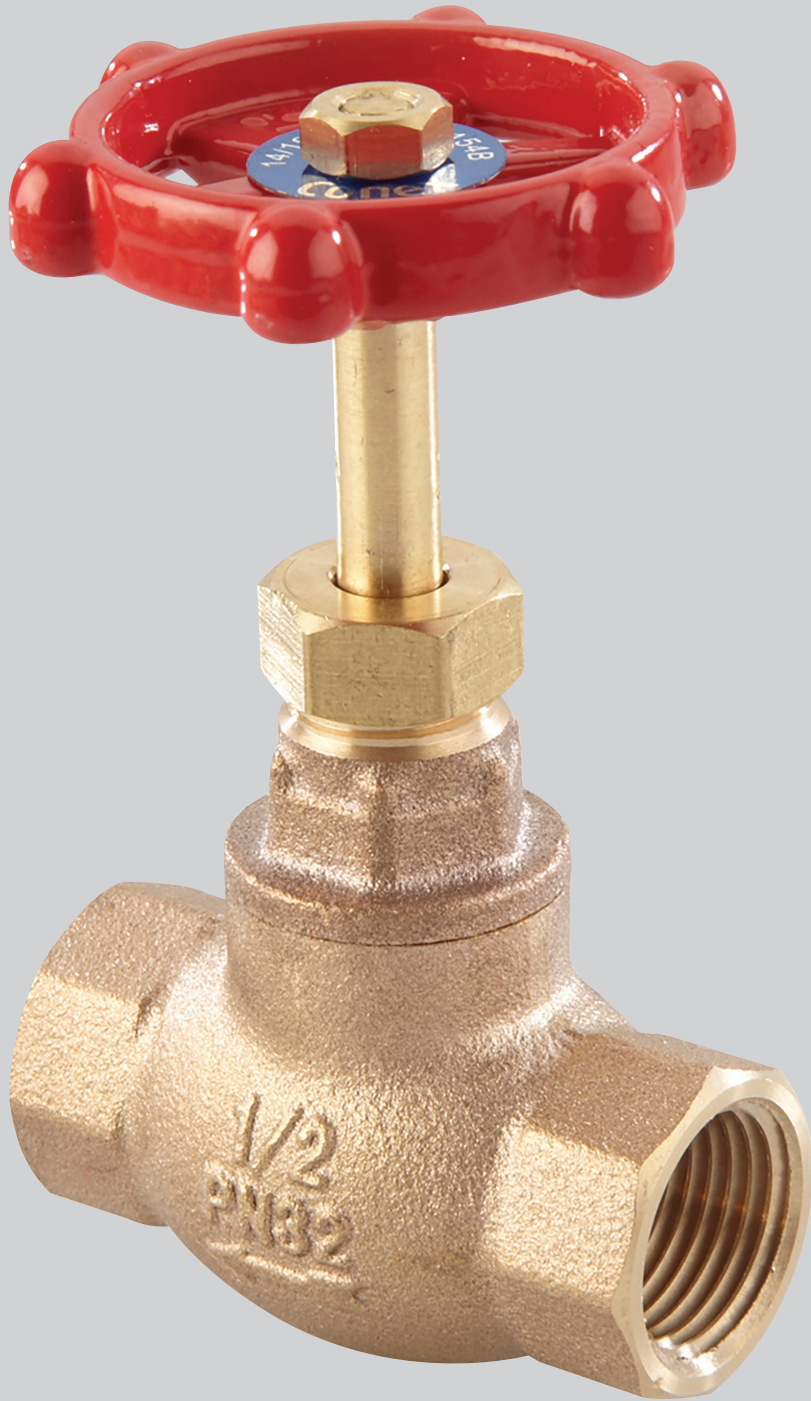

4.0 Globe Valves

Conex Bänninger Globe Valves are used to stop, open or throttle the flow of the fluid in the system.

Globe valves enable proportional control (flow characteristics) as the relationship between flow rate and the extent of valve lift is linear. Conex Bänninger offers two basic seat and disc configurations, as follows:

- Renewable composition or soft seat (series 1130)
- Metal to metal seat (series 1131)

Soft seated valves are recommended when the valve is to be used with gasses to ensure a complete shut-off to be achieved. Flow direction should normally be with the pressure under the seat.

Conex Bänninger Globe Valves are manufactured in accordance with EN 5154:1991 Series B, PN32.

Application and uses

Globe valves are used for applications requiring throttling and frequent operation. For example, globe valves may be used as sampling valves, which are normally shut except when liquid samples are being taken. Since the baffle restricts flow, they are not recommended where full, unobstructed flow is required.

Valve materials

Conex Bänninger Globe Valves are manufactured from bronze and are suitable for a broad range of applications as they are classed as immune to dezincification, stress corrosion cracking and are highly corrosion resistant. Stress corrosion cracking occurs occasionally in brass valves where high levels of stress in the component are combined with a corrosive environment causing cracks to form and grow. Common corrosive environments for brass are items that contain ammonia, or ammoniacal compounds. These can be found in cleaning fluids, refrigeration gases, sewage waste products, building materials and insulating materials.

For further information refer to stress corrosion cracking at www.conexbanninger.com/standards



1130 Globe Valve - Resilient Seat PN32 - (bronze)

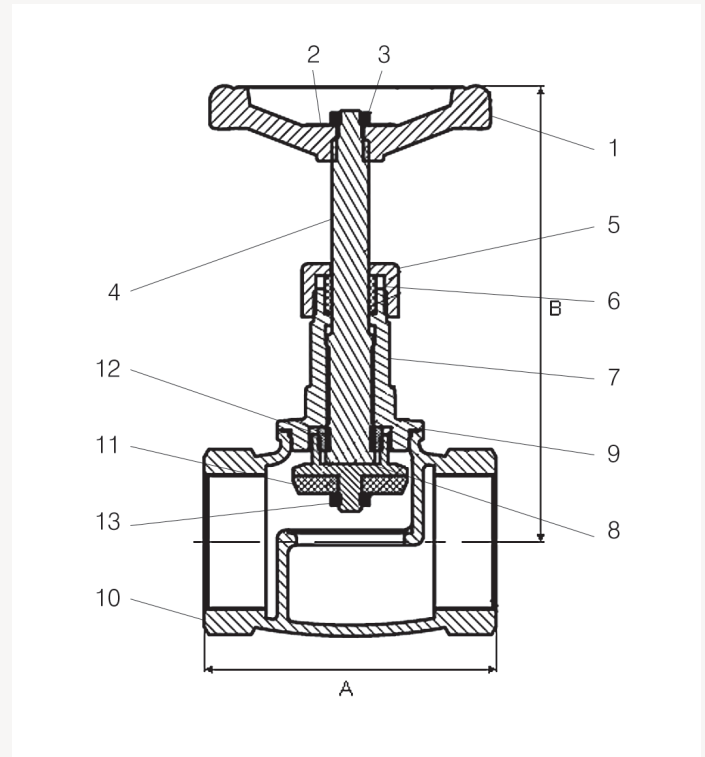

Material specification

1130 Handwheel version 1/2" to 4"

No	Component	Material	Specification
1	Handwheel	Aluminium	EN 1706 LM6
2	Rating disc	Aluminium	EN 1706 LM6
3	Handwheel nut	Brass	EN 12164CW614N
4	Stem	Bronze	EN 1982 CC491K
5	Packing nut	Brass	EN 12165 CW617N-DW
6	Packing	PTFE	PTFE
7	Bonnet	Bronze	EN 1982 CC491K
8	Core	DZR brass	EN 12164 CW602N
9	Bonnet washer	Brass	EN 12165 CW617N-DW
10	Body	Bronze	EN 1982 CC491K
11	Seat	PTFE	PTFE
12	Core retention nut	Brass	EN 12165 CW617N-DW
13	Seat nut	Brass	EN 12165 CW617N-DW

Features and benefits:

- WRAS approved for drinking water systems.
- Provides accurate regulation and control of flow.
- Rising stem design.
- High quality bronze construction.
- Robust and compact design.
- End connections, female taper threads to EN 10226-2 (ISO 7-1) and parallel threads to ISO 228.
- Suitable for use with low temperature hot water and chilled systems.
- Sizes 1 1/4" and above are CE marked – Category 1.

1130 Globe Valve

Order code EN 10226-2 (ISO7-1) thread	Order code ISO 228 thread	Size	DN	A	B	Kv value	Weight (kg)
11302RRW320404	11302FFW320404	1/2"	15	60	95	2.9	0.30
11302RRW320606	11302FFW320606	3/4"	20	65	100	-	0.54
11302RRW320808	11302FFW320808	1"	25	80	115	12	0.84
11302RRW321010	11302FFW321010	1.1/4"	32	90	135	-	1.36
11302RRW321212	11302FFW321212	1.1/2"	40	100	155	-	1.76
11302RRW321616	11302FFW321616	2"	50	120	174	72	2.97
11302RRW322020*	11302FFW322020*	2.1/2"	65	145	-	-	4.14
11302RRW322424*	11302FFW322424*	3"	80	200	-	-	5.68

*Valves available to special order.

Valve suitability

Product	Steam	Water	Drinking water	Oil	Air (oil free)	Gas (inert)	Gas (combustible)	Gas (corrosive)	Gas (oxygen)
1130	x	✓	✓	✓	✓*	✓*	✓*	✓*	x

* Limited to 10 bar.

Max. working parameters

1130	Temperature °C	Pressure bar	Pressure psi
Water	-10 to +100	32	460
Gas	-10 to +60	5	70

Gas family application guide

- Class 1: Inert – Air, Argon, Helium, Nitrogen and Carbon Dioxide.
- Class 2: Combustible – Hydrogen, Methane and Natural Gas.
- Class 3: Corrosive – Sulphur Dioxide.
- Class 4: Oxygen.

Specification clauses:

- Manufactured in accordance with EN 5154: 1991 Series B, PN32.
- Design incorporates a replaceable resilient seat disc retained on the stem by a nut.
- Body seat is integral to the body.
- Handwheel operated.
- End connections, female taper threads to EN 10226-2 (ISO 7-1) and parallel threads to ISO 228.
- WRAS approved for drinking water systems.
- Suitable for low temperature hot water and chilled systems.

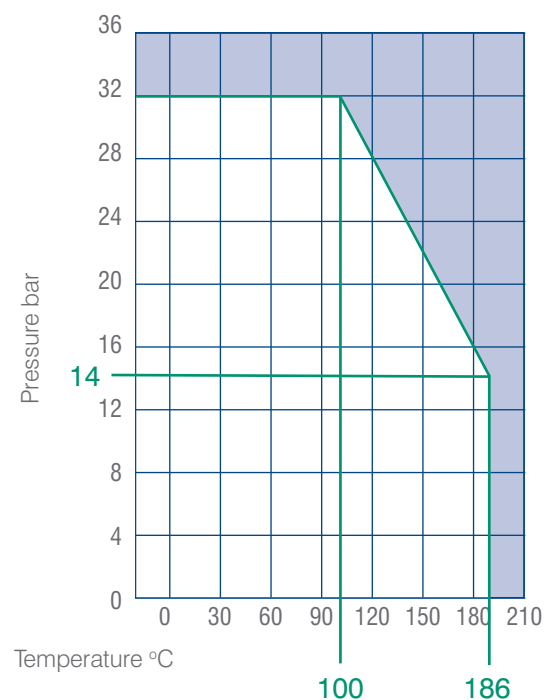

1131 Globe Valve - Metal to Metal Seat PN32 - (bronze)

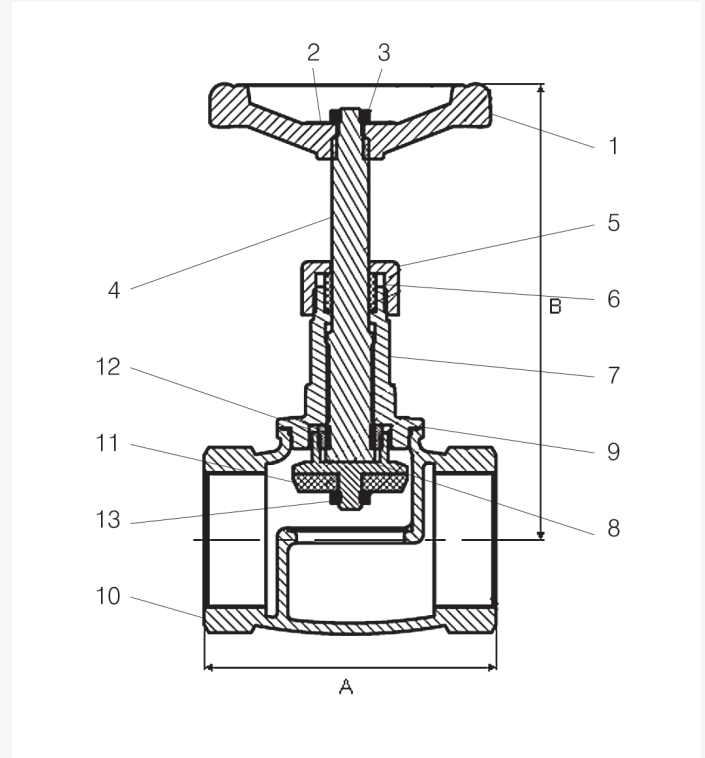

Material specification

1131 Handwheel version 1/2" to 4"

No	Component	Material	Specification
1	Handwheel	Aluminium	EN 1706 LM6
2	Rating disc	Aluminium	EN 1706 LM6
3	Handwheel nut	Brass	EN 12165 CW614N
4	Stem	Bronze	EN 1982 CC491K
5	Packing nut	Bronze	EN 12165 CW617N-DW
6	Packing	PTFE	PTFE
7	Bonnet	Bronze	EN 1982 CC491K
8	Core	DZR brass	EN 12164 CW602N
9	Bonnet washer	PTFE	PTFE
10	Body	Bronze	EN 1982 CC491K

Features and benefits:

- Designed in accordance with EN 5154.
- WRAS approved for drinking water systems.
- Provides accurate regulation and control of flow.
- Rising stem design.
- High quality bronze construction.
- Robust and compact design.
- End connections, female taper threads to EN 10226-2 (ISO 7-1) and parallel threads to ISO 228.
- Approved for drinking water applications.
- Suitable for use with low temperature hot water and chilled systems.

1131 Globe Valve

Order code EN 10226-2 (ISO 7-1) thread	Order code ISO 228 thread	Size	DN	A	B	Kv value	Weight (kg)
113120RRW320404	113120FFW320404	1/2"	15	60	95	2.9	0.31
113120RRW320606	113120FFW320606	3/4"	20	65	100	-	0.54
113120RRW320808	113120FFW320808	1"	25	80	115	12	0.84
113120RRW321010	113120FFW321010	1.1/4"	32	90	135	-	1.36
113120RRW321212	113120FFW321212	1.1/2"	40	100	155	-	1.76
113120RRW321616	113120FFW321616	2"	50	120	174	72	2.62
113120RRW322020*	113120FFW322020*	2.1/2"	65	145	-	-	4.14
113120RRW322424*	113120FFW322424*	3"	80	200	-	-	5.68
113120RRW323232*	113120FFW323232*	4"	100	-	-	-	-

*Valves available to special order.

Valve suitability

Product	Steam	Water	Drinking water	Oil	Air (oil free)	Gas (inert)	Gas (combustible)	Gas (corrosive)	Gas (oxygen)
1131	x	✓	✓	✓	✓	x	x	x	x

Max. working parameters

1131	Temperature °C	Pressure bar	Pressure psi
Water	-10 to +100	32	460

Specification clauses:

- Manufactured in accordance with EN 5154: 1991 Series B, PN32.
- Design incorporates a metal seat disc retained on the stem.
- Body seat is integral to the body.
- Handwheel operated.
- End connections, female taper threads to EN 10226-2 (ISO 7-1) and parallel threads to ISO 228.
- WRAS approved for drinking water systems.
- Suitable for low temperature hot water and chilled systems.

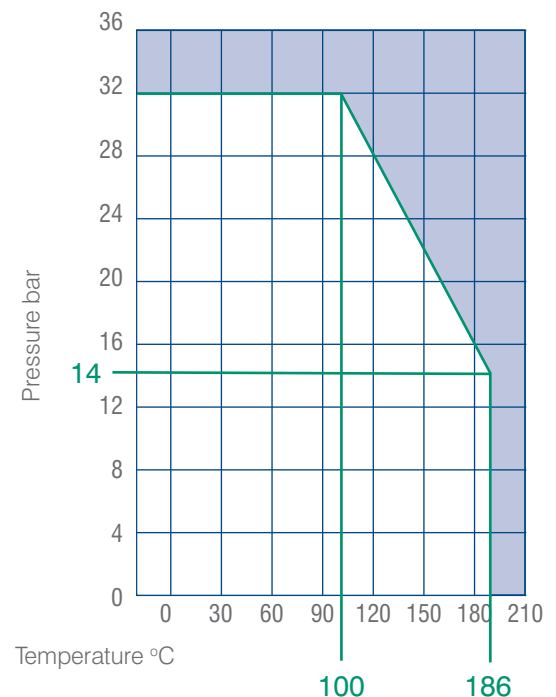



5.0 Balancing Valves

The balancing valve ensures constant flow rate irrespective of changing pressure conditions. Only an accurately set series of balancing valves can ensure the correct distribution of flow in the system.

Static balancing valves

Manual balancing valves are used to balance the flow of water in hydronic heating and cooling systems. Manual balancing valves can be set by calculating the desired setting or by

measuring the flow rate and adjusting to the desired value. By throttling (potential) overflows in the system a proper distribution of the available pump capacity is ensured.



BSSX Fixed Orifice Double Regulating Valve PN25

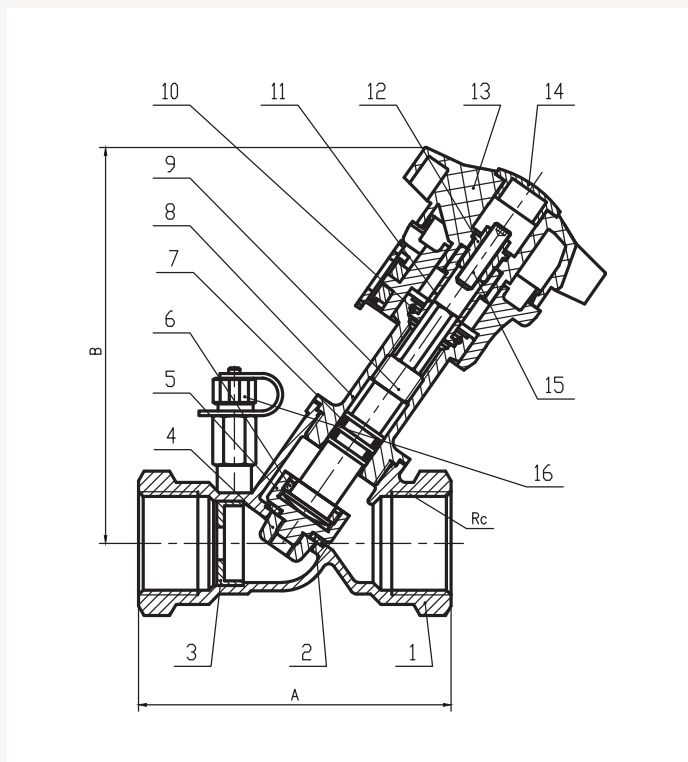

Material specification

BSSX Fixed Orifice Double Regulating Valve PN 25 1/2" to 2"

No	Component	Material
1	Body	Bronze CC491K
2	Disc face	PTFE*
2	Disc face	DZR brass CW602N**
3	Orifice plate	DZR brass CW602N
4	Nut	DZR brass CW602N
5	Disc	DZR brass CW602N
6	Disc retaining ring	DZR brass CW602N
7	O-ring	NBR
8	Bonnet	DZR brass CW602N***
8	Bonnet	Bronze CC491K****
9	Stem	DZR brass CW602N
10	Retainer ring	Stainless steel 304
11	Sleeve	Brass CW617N
12	Screw	Brass CW617N
13	Handwheel	Polyamide nylon
14	Cap	Polyamide nylon
15	Screw	Stainless steel 304
16	Test points	DZR brass CW602N

*1" to 2", **1/2" to 3/4", ***1/2" - 1 1/4", ****1 1/2" - 2"

Balancing Valves

Applicable standards:

- Product standard: BS 7350.
- End connection threads: ISO 07-1 female taper BSPT threads.

Technical data:

- Size: DN 15 to DN 50 (1/2" to 2").
- Nominal pressure: 25 bar.
- Temperature range: -10 °C to 120 °C.
- Suitable for water and water / glycol up to 45%.

Features and benefits:

- Corrosion resistant bronze body, suitable for heating and cooling applications.
- Y type body design with characterised throttling disc tending towards equal percentage performance.
- Operation by means of microset handwheel.
- Tamperproof setting, allen key.
- Fixed orifice double regulating valve offers an accuracy of + 5% on all settings, for precise flow regulation.
- Two pressure tapping points for flow measuring equipment.
- The valve may be installed in horizontal, vertical or inclined pipework.

BSSX Fixed Orifice Double Regulating Valve PN 25 1/2" to 2"

Order code	Size	DN	A	B	Coefficients	
					Flow (kv)	Kvs
D0015DTBSHMSRO	1/2"	15	87	105	1.72	2.2
D0020DTBSHMSRO	3/4"	20	96	106	2.97	4.6
D0025DTBSHMSRO	1"	25	100	127	4.75	8.5
D0032DTBSHMSRO	1 1/4"	32	114	128	10.25	16.7
D0040DTBSHMSRO	1 1/2"	40	125	143	16.83	26.1
D0050DTBSHMSRO	2"	50	146	144	27.26	43.2

Valve opening, indication and regulation

The valve may be installed in horizontal, vertical or inclined pipework. The direction arrow on the body must be installed in line with the direction of the flow in the pipeline. Five diameters of straight pipe of the same nominal diameter as the valve must be present upstream of the valve and three diameters downstream. The valve is equipped with two test points and is distributed in the open position (handwheel turns open DN15 to DN50 four turns). Flow regulation is achieved by adjusting the valve setting until the required flowrate, as derived from the "signal" measured across the pressure test points is obtained. The microset handwheel will indicate the final valve setting.

BSPX Static Balancing Valve PN16 flanged

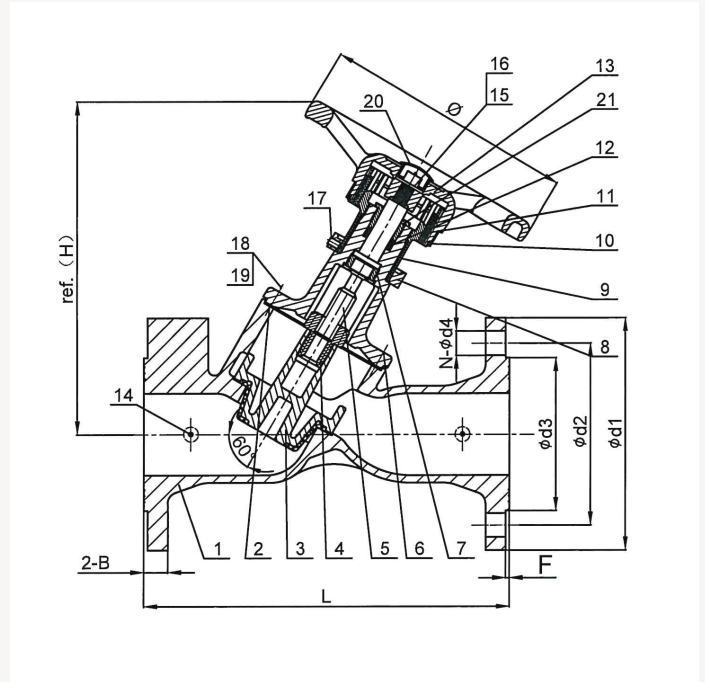

Material specification

BSPX Static Balancing Valve Flanged 2 1/2" to 12"

No	Component	Material
1	Body	Ductile iron EN-JS 1040
2	Seal gasket	EPDM
3	Disc	Ductile iron EN-JS 1040 + EPDM
4	Stem nut	Brass EN 12165 CW617N
5	Stem	Stainless steel BS970 410S21 (DN65-DN300) Stainless steel BS970 431S21 (DN350-DN600)
6	Cover	Ductile iron EN-JS 1040
7	Stem lock bushing	Brass EN 12165 CW617N
8	Limit set indicator	Brass EN 12165 CW617N + galvanized (DN65-DN300) Stainless steel BS970 304S15 (DN350-DN600)
9	Printed set indicator	Brass EN 12165 CW617N
10	Directed circle	ABS
11	Indicator	ABS
12	Packing	PTFE + EPDM
13	Handwheel	Ductile iron EN-JS 1040
14	Plug	Steel
15	Bolt	Stainless steel BS970 304S15
16	Big gasket	Stainless steel BS970 304S15
17	Hexagon socket screws	Stainless steel BS970 304S15
18	Bolt	Stainless steel BS970 304S15
19	Spring gasket	Stainless steel BS970 304S15
20	Indicator dust cover	ABS
21	Packing gland	Brass EN 12165 CW617N (DN65-DN150) Ductile iron EN-JS 1040 (DN200-DN600)

Applicable standards:

- Product standard: BS 7350.
- Flanges standard: EN 1092-2.
- Face to face standard: EN 558-1.

Technical data:

- Size: DN 65 - DN 300 (2 1/2" - 12").
- Nominal pressure: PN16.
- Shell test pressure: 24 bar.
- Seat test pressure: 17.6 bar.
- Temperature range: -10 °C to 120 °C.
- Suitable for water and water/glycol.

Features and benefits:

- Available in sizes 2 1/2" - 12", sizes 14" up to 20" available to special order please contact your local Conex Bänninger representative.
- Y type body design allows higher flow rate, 15 - 20% more than T type.
- Full shut-off for zero leakage.
- Manufactured from high quality ductile iron.
- Suitable for water and water/glycol applications.
- Designed and manufactured in accordance with BS 7350.
- Designed with multiple pressure tapping points for flow testing equipment.
- Tamperproofing via lockable handwheel.
- Variable orifice body for accurate regulation and easy presetting.
- Electrostatically coated with corrosion resistant epoxy powder internally and externally. Minimum coating thickness 250 microns.

BSPX Static Balancing Valve Flanged 2 1/2" - 12"

Order Code	Size	DN	H	L	B	Ø	Ød1	Ød2	Ød3	N-Ød4	F	Coefficients	
												Flow Kv	Head K
D0065CFDSH01RO	2 1/2"	65	265	290	19	200	185	145	118	4- Ø19	3	83.8	3.78
D0080CFDSH01RO	3"	80	270	310	19	200	200	160	132	8- Ø19	3	119.5	5.24
D0100CFDSH01RO	4"	100	310	350	19	240	220	180	156	8- Ø19	3	178.7	9.53
D0125CFDSH01RO	5"	125	340	400	19	290	250	210	184	8- Ø19	3	272.7	6.98
D0150CFDSH01RO	6"	150	340	480	19	290	285	240	211	8- Ø23	3	380.0	5.35
D0200CFDSH01RO	8"	200	537	600	20	350	340	295	266	12- Ø23	3	608.0	6.26
D0250CFDSH01RO	10"	250	570	730	22	420	405	355	319	12- Ø28	3	1292.0	5.57
D0300CFDSH01RO	12"	300	690	850	24.5	420	460	410	370	12- Ø28	4	1791.5	6.43

Valve opening, indication and regulation

DN65 - 150 valves operate from closed to fully open with eight complete turns of the microset handwheel, twelve turns for DN 200 – 250 and eighteen turns for DN300. The microset handwheel indicates the valve setting by means of digits appearing in outer and inner windows. The digit in the outer window indicates tenths of a turn. Flow regulation is achieved by adjusting the valve setting until the required flowrate, as derived from the "signal" measured across the pressure test points is obtained. The microset handwheel will indicate the final valve setting.



6.0 Y-Pattern Strainer Valves

Conex Bänninger Y-Pattern Strainer Valves are manufactured from brass, bronze or ductile iron. Ductile iron valves are electrostatically coated with corrosion resistant epoxy powder internally and externally.

During installation and subsequent operation dirt and scale can cause considerable damage to pipeline systems. The use of Conex Bänninger Y-Pattern Strainers will assist in reducing any problems caused by foreign bodies in the pipeline. The design of the strainer body has been created to minimise the pressure drop across the valve by using a curved profile which assists in reducing turbulence. Conex Bänninger strainers are sized to allow the valve to collect a reasonable amount of material before pressure reductions require the strainer to be cleaned.



1802 Y-Pattern Strainer PN16 - (brass)

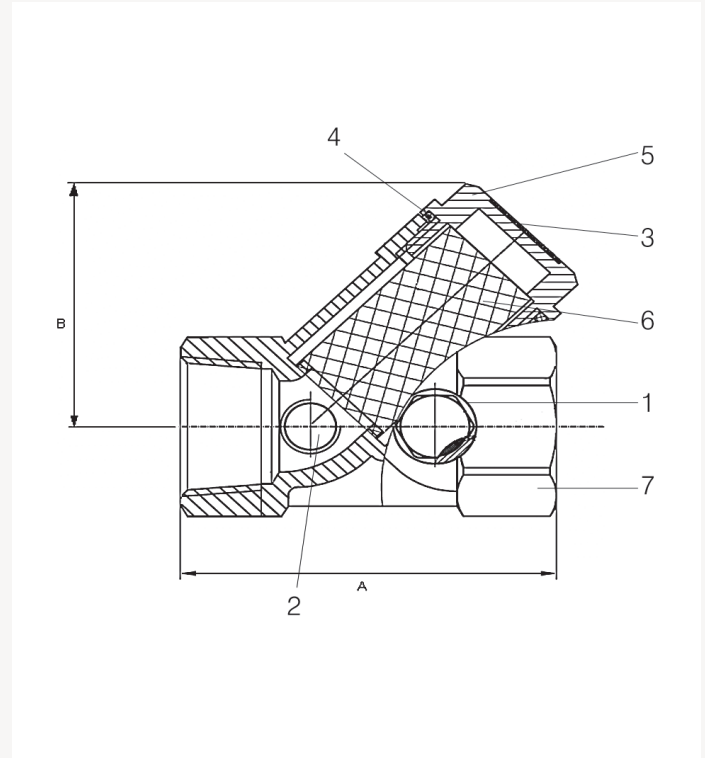

Material specification

1802 Y-Pattern Strainer 1/2" to 4"			
No	Component	Material	Specification
1	O-ring	EPDM	EN 2430: 1995
2	Blanking plug*	DZR brass	EN 12164 CW602N
3	Rating disc	Aluminium	EN 1706 LM6
4	Washer	PTFE	PTFE
5	Cap	Brass	EN 12165 CW617N-DW
6	Filter screen	Stainless steel	ISO 15510
7	Body	Brass	EN 12165 CW617N-DW

*Drilled and tapped bosses to special order.

Y-Pattern Strainer Valves

Features and benefits:

- Streamlined design in order to minimise pressure drop.
- Stainless steel mesh, density 350 holes per square inch.
- Robust and compact design.
- Available with drilled and tapped bosses to special order.
- End connections taper threads to EN 10226-2 (ISO 7-1) and parallel threads to ISO 228.
- WRAS approved for drinking water applications.
- Suitable for low temperature hot water systems.

1802 Y-pattern Strainer

Order code EN 10226-2 (ISO 7-1) thread	Order code ISO 228 thread	Size	DN	A	B	Kv value	Weight (kg)
180210RR0160404	180210FF0160404	1/2"	15	65	42	2.35	0.152
180210RR0160606	180210FF0160606	3/4"	20	75	50	3.3	0.246
180210RR0160808	180210FF0160808	1"	25	90	56	6.5	0.358
180210RR0161010	180210FF0161010	1.1/4"	32	110	65	11	0.584
180210RR0161212	180210FF0161212	1.1/2"	40	120	75	13.5	0.868
180210RR0161616	180210FF0161616	2"	50	135	90	15.6	1.270
180210RR0162020*	180210FF0162020*	2.1/2"	65	-	-	-	-
180210RR0162424*	180210FF0162424*	3"	80	-	-	-	-
180210RR0163232*	180210FF0163232*	4"	100	-	-	-	-

*Valves available to special order.

Valve suitability

Product	Steam	Water	Drinking water	Oil	Air (oil free)	Gas (inert)	Gas (combustible)	Gas (corrosive)	Gas (oxygen)
1802	x	✓	✓	✓	x	x	x	x	x

The fluid to be transported is limited to Group 2 liquids i.e. non-hazardous and on no account should these valves be used for any Group 2 Gases, Group 1 Liquids or Group 1 Gases.

Max. working parameters

1802	Temperature °C	Pressure bar	Pressure psi
Water	-10 to +100	16	230

Specification clauses:

- Brass body.
- Brass screw in cap.
- Stainless Steel SS304 screen, density 350 holes per square inch.
- Test pressure 24 bar hydraulic.
- End connections, female taper threads to EN 10226-2 (ISO 7-1) and parallel threads to ISO 228.
- WRAS approved for drinking water applications.

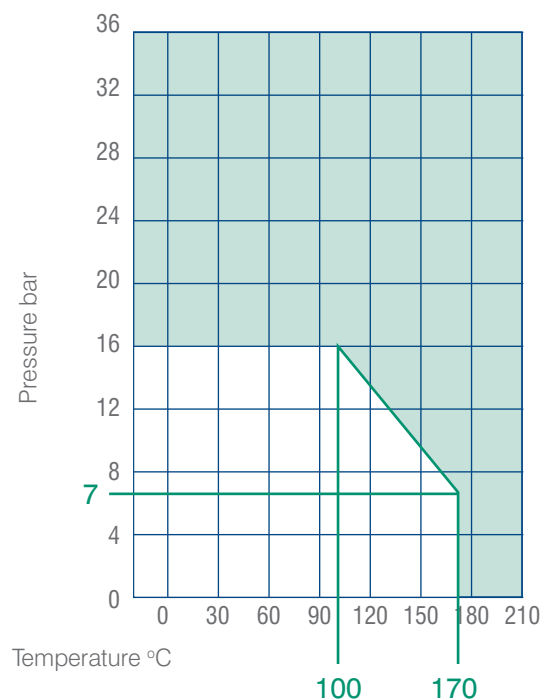

1804 Y-Pattern Strainer PN16 - (brunze)

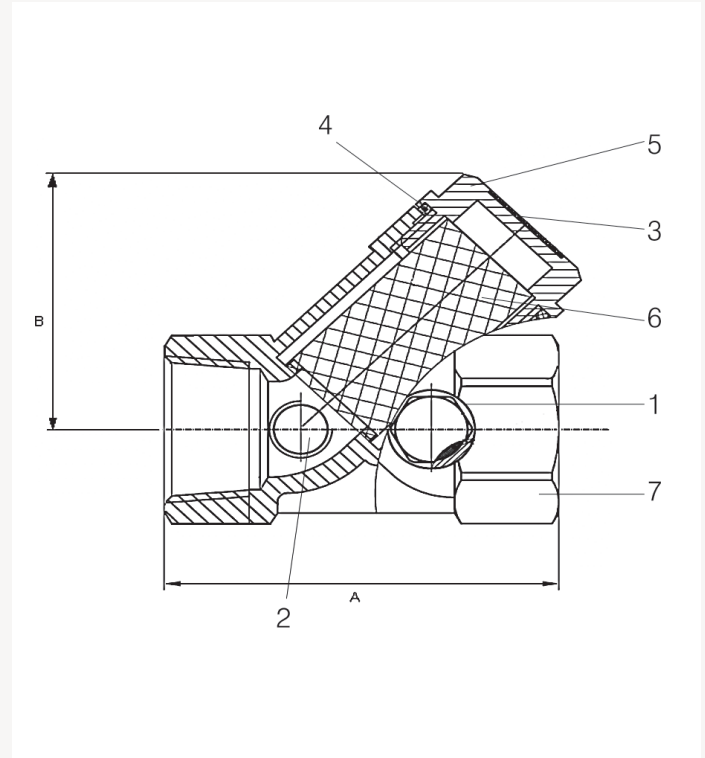

Material specification

1804 Y-Pattern Strainer 1/2" to 4"			
No	Component	Material	Specification
1	O-ring	EPDM	EN 2430: 1995
2	Blanking plugs*	DZR brass	EN 12164 CW602N
3	Rating disc	Aluminium	EN 1706 LM6
4	Washer	PTFE	PTFE
5	Cap	Bronze	EN 1982 CC491K
6	Screen	Stainless steel	ISO 15510
7	Body	Bronze	EN 1982 CC491K

*Drilled and tapped bosses to special order.

Features and benefits:

- Streamlined design in order to minimise pressure drop.
- Available with drilled and tapped bosses to special order.
- Suitable for low temperature hot water and chilled systems.
- Bronze body with streamlined internal contour to minimise pressure drop across valve.
- End connections, female taper threads to EN 10226-2 (ISO 7-1) and parallel threads to ISO 228.
- Stainless steel mesh, density 350 holes per square inch.
- WRAS approved for drinking water applications.

1804 Y-Pattern Strainer

Order code EN 10226-2 (ISO 7-1) thread	Order code ISO 228 thread	Size	DN	A	B	Kv value	Weight (kg)
180420RR0160404	180420FF0160404	1/2"	15	65	42	2.35	0.21
180420RR0160606	180420FF0160606	3/4"	20	75	50	3.3	0.32
180420RR0160808	180420FF0160808	1"	25	90	56	6.5	0.48
180420RR0161010	180420FF0161010	1.1/4"	32	110	65	11	0.76
180420RR0161212	180420FF0161212	1.1/2"	40	120	75	13.5	1.00
180420RR0161616	180420FF0161616	2"	50	135	90	15.6	1.61
180420RR0162020*	180420FF0162020*	2.1/2"	65	-	-	-	-
180420RR0162424*	180420FF0162424*	3"	80	-	-	-	-
180420RR0163232*	180420FF0163232*	4"	100	-	-	-	-

*Valves available to special order.

Valve suitability

Product	Steam	Water	Drinking water	Oil	Air (oil free)	Gas (inert)	Gas (combustible)	Gas (corrosive)	Gas (oxygen)
1804	x	✓	✓	✓	x	x	x	x	x

The fluid to be transported is limited to Group 2 liquids i.e. non-hazardous and on no account should these valves be used for any Group 2 Gases, Group 1 Liquids or Group 1 Gases.

Max. working parameters

1804	Temperature °C	Pressure bar	Pressure psi
Water	-10 to +100	16	230

Specification clauses:

- Bronze body.
- Bronze screw in cap.
- Stainless steel SS304 screen, density 350 holes per square inch.
- End connections, female taper threads to EN 10226-2 (ISO 7-1) and parallel threads to ISO 228.
- WRAS approved for drinking water applications.
- Suitable for low temperature hot water and chilled systems.

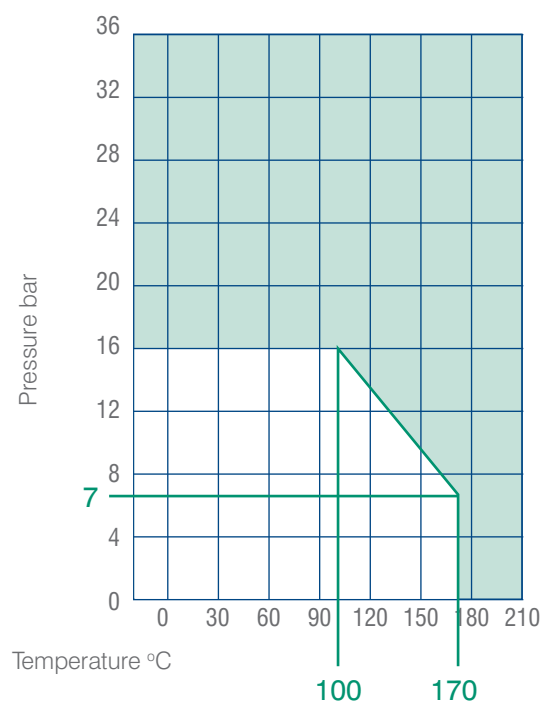

YSTF Y-Pattern Strainer Valves PN16 flanged

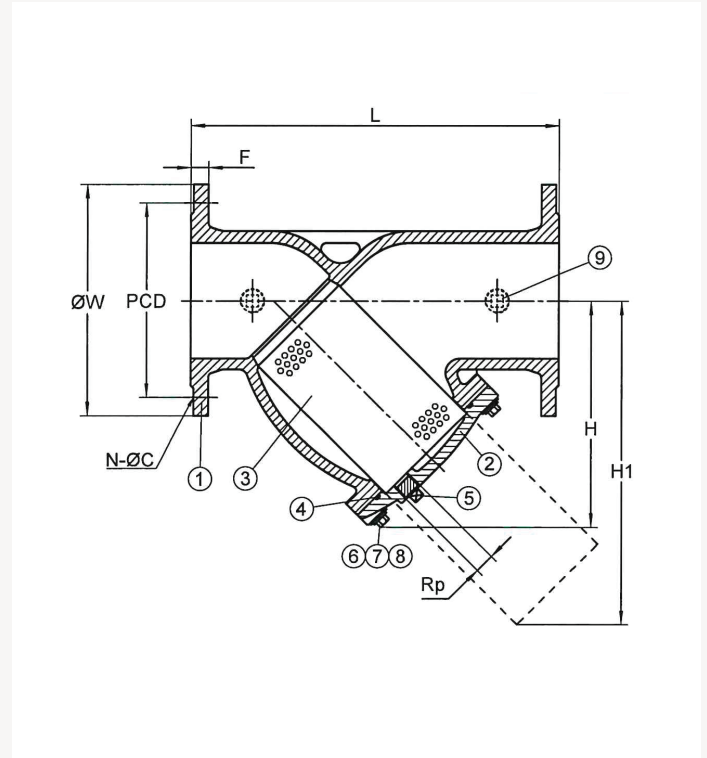

Material specification

YSTF Y-Pattern Strainer Valves Flanged 2" to 16"			
No	Component	Material	
1	Body	Ductile iron	
2	Cover	Ductile iron	
3	Screen	Stainless steel SS304	
4	Packing	EPDM	
5	Drain plug	Stainless steel SS304	
6	Bolt	Carbon steel	
7	Spring washer	Spring steel 65 Mn	
8	Washer	Carbon steel	
9	Test point plug 1/4"	Stainless steel SS304	

Note: Test points not configured on standard product.

Applicable standards:

- Connection standard: EN 1092-2.
- Pressure test standard: EN 12266-1.
- Face to face dimensions:
EN 558 Series 1.

Technical data:

- Size: DN 50 – DN 400 (2" - 16").
- Nominal pressure: PN16.
- Shell test pressure: 24 bar.
- Seat test pressure: 17.6 bar.
- Temperature range: -10 °C to 120 °C.
- Suitable for: Water and neutral liquids.

Features and benefits:

- Manufactured from high quality ductile iron.
- Screen is punched stainless steel plate.
- Mesh diameter varies with valve size.
- Drain point to enable draining of debris from trapped inside screen.
- Electrostatically coated with corrosion resistant epoxy powder internally and externally. Minimum coating thickness 250 microns.

YSTF Y-Pattern Strainer Valves Flanged 2" to 16"

Order Code	Size	DN	L	H	H1	Rp Drain plug	Mesh Dia.	F	ØW	EN 1092-2 PN16	
										PCD	N-ØC
Y0050CFCMN01SO	2"	50	230	124	183	3/8"	1.5	18	165	Ø125	4-Ø19
Y0065CFCMN01SO	2 1/2"	65	290	137	205	3/8"	1.5	18	185	Ø145	4-Ø19
Y0080CFCMN01SO	3"	80	310	152	238	3/8"	1.5	18	200	Ø160	8-Ø19
Y0100CFCMN01SO	4"	100	350	205	318	3/8"	1.5	18	220	Ø180	8-Ø19
Y0125CFCMN01SO	5"	125	400	244	358	3/8"	1.5	18	250	Ø210	8-Ø19
Y0150CFCMN01SO	6"	150	480	269	380	3/8"	1.5	18	285	Ø240	8-Ø23
Y0200CFCMN01SO	8"	200	600	341	508	1/2"	2.5	19	340	Ø295	12-Ø23
Y0250CFCMN01SO	10"	250	730	455	700	1/2"	2.5	22	405	Ø355	12-Ø28
Y0300CFCMN01SO	12"	300	850	476	730	1/2"	2.5	24.5	460	Ø410	12-Ø28
Y0350CFCMN01SO	14"	350	980	725	1130	3/4"	2.5	26.5	520	Ø470	16-Ø28
Y0400CFCMN01SO	16"	400	1100	820	1285	3/4"	3.5	28	580	Ø525	16-Ø31



7.0 Quarter Turn Ball Valve

Conex Bänninger offers a comprehensive range of quarter turn ball valves which are designed for easy and quick operation, requiring only a quarter turn to be either fully opened or closed.

The range includes both lever and 'T' handle variants, and also offers products for both water and gas applications. Conex Bänninger Ball Valves are full bore valves which incorporate an oversized ball to allow the hole in the centre to be equal in diameter to that of the pipeline. This results in low friction losses and flows similar to that of the pipe.

Durable and reliable

Ball valves by nature of their design are extremely durable and reliable even after many years of service. Quarter turn ball valves can be opened and closed quickly. This makes them the preferred choice for isolation applications where a quick shut-off is required or the valves are used frequently. Ball valves excel at isolation, but are inaccurate for applications which require flow control. Where this is necessary, Conex Bänninger Globe Valves should be considered.

Materials

Conex Bänninger Quarter Turn Ball Valves are available in brass, chrome plated brass or DZR. Additionally, all balls within the range are chrome plated for added corrosion resistance and for low torque operation.



1200 Quarter Turn Ball Valve - PN25 (DZR) - red lever

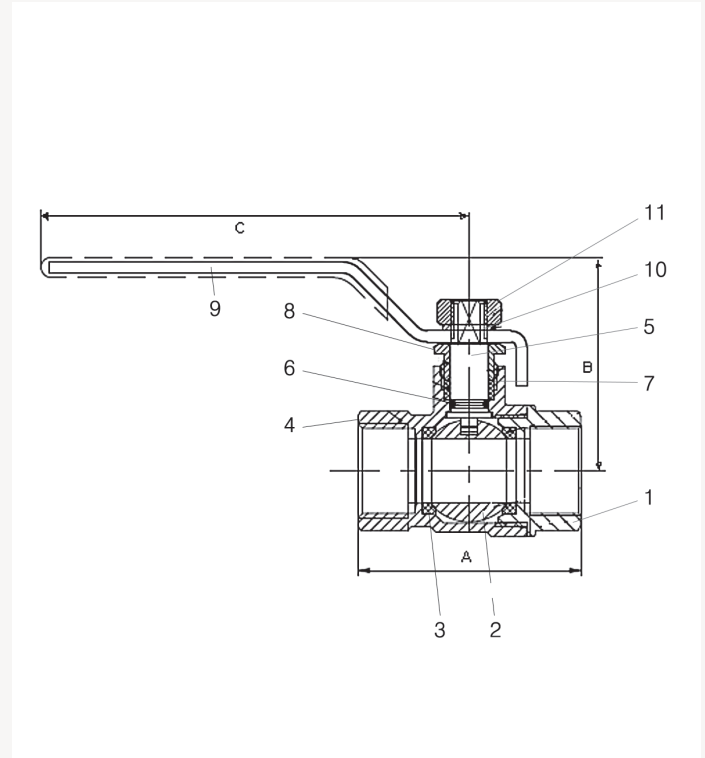

Material specification

1200 Lever handle version 1/2" to 2"			
No	Component	Material	Specification
1	End connector	DZR brass	EN 12165 CW602N
2	Ball	Brass - chrome plate	EN 12165 CW617N-DW
3	Ball seal	PTFE	PTFE
4	Body	DZR brass	EN 12165 CW602N
5	Stem	DZR brass	EN 12164 CW602N
6	Stem O-ring	EPDM	EN 2430: 1995
7	Gland	PTFE	PTFE
8	Packing nut	Brass	EN 12164 CW617N-DW
9	Lever handle	Steel	EN 24T + polyethylene HD
10	Washer	Stainless steel	ISO 15510
11	Lever nut	Stainless steel	ISO 15510

Features and benefits:

- Full bore quarter turn ball valve.
- Blow out proof stem.
- Full DZR construction.
- End connections, female taper threads to EN 10226-2 (ISO 7-1) and parallel threads to ISO 228.
- WRAS approved for drinking water applications.
- Suitable for low temperature hot water and chilled systems.
- Unique Conex Bänninger lever handle.

1200 Ball Valve									
Order code EN 10226-2 (ISO 7-1) thread	Order code ISO 228 thread	Size	DN	A	B	C	Kv value	Weight (kg)	
120050RRR250404	120050FFR250404	1/2"	15	55	48	95	16	0.208	
120050RRR250606	120050FFR250606	3/4"	20	65	52	95	30	0.332	
120050RRR250808	120050FFR250808	1"	25	78	65	130	48	0.602	
120050RRR251010	120050FFR251010	1.1/4"	32	91	69	130	100	0.927	
120050RRR251212	120050FFR251212	1.1/2"	40	99	80	160	170	1.362	
120050RRR251616	120050FFR251616	2"	50	119	88	160	230	2.224	

Valve suitability									
Product	Steam	Water	Drinking water	Oil	Air (oil free)	Gas (inert)	Gas (combustible)	Gas (corrosive)	Gas (oxygen)
1200	x	✓	✓	✓	✓	x	x	x	x

This valve is not suitable for gas applications.

Max. working parameters			
Product	Temperature °C	Pressure bar	Pressure psi
1200 Water	-10 to +120	25	360

Specification clauses:

- Lever operated quarter turn, tight shut-off.
- DZR brass body, stem and end connector.
- Chrome plated brass ball.
- PTFE seats and stem gland seal.
- End connections, female taper threads to EN 10226-2 (ISO 7-1) and parallel threads to ISO 228.
- WRAS approved for drinking water applications.
- EPDM stem O-ring.
- Suitable for low temperature hot water and chilled systems.

1205 Quarter Turn Ball Valve PN25 - (DZR) - red tee

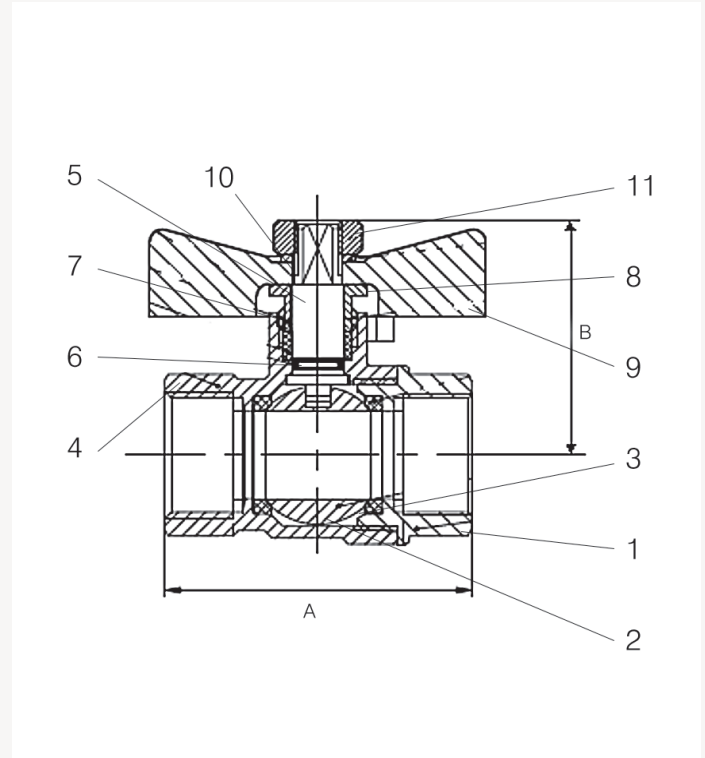

Material specification

1205 Tee handle version 1/2" to 1"			
No	Component	Material	Specification
1	End connector	DZR brass	EN 12165 CW602N
2	Ball	Brass - chrome plate	EN 12165 CW617N-DW
3	Ball seal	PTFE	PTFE
4	Body	DZR brass	EN 12165 CW602N
5	Stem	DZR brass	EN 12164 CW602N
6	Stem O-ring	EPDM	EN 2430: 1995
7	Gland	PTFE	PTFE
8	Packing nut	Brass	EN 12164 CW617N-DW
9	Tee handle	Aluminium	EN 1706 LM6
10	Washer	Stainless steel	ISO 15510
11	Lever nut	Stainless steel	ISO 15510

Features and benefits:

- Full bore quarter turn ball valve.
- Blow out proof stem.
- Full DZR construction.
- End connections, female taper threads to EN 10226-2 (ISO 7-1) and parallel threads to ISO 228.
- WRAS approved for drinking water applications.
- Suitable for low temperature hot water and chilled systems.

1205 Ball Valve

Order code EN 10226-2 (ISO 7-1) thread	Order code ISO 228 thread	Size	DN	A	B	Kv value	Weight (kg)
120550RRT250404	120550FFT250404	1/2"	15	55	38	16	0.187
120550RRT250606	120550FFT250606	3/4"	20	65	42	30	0.332
120550RRT250808	120550FFT250808	1"	25	78	50	48	0.590

Valve suitability

Product	Steam	Water	Drinking water	Oil	Air (oil free)	Gas (inert)	Gas (combustible)	Gas (corrosive)	Gas (oxygen)
1205	x	✓	✓	✓	✓	x	x	x	x

This valve is not suitable for gas applications.

Max. working parameters

1205	Temperature °C	Pressure bar	Pressure psi
Water	-10 to +120	25	360

Specification clauses:

- Tee operated quarter turn, tight shut-off.
- DZR brass body, stem and end connector.
- Chrome plated brass ball.
- PTFE seats and stem gland seal.
- EPDM stem O-ring.
- End connections, female taper threads to EN 10226-2 (ISO 7-1) and parallel threads to ISO 228.
- WRAS approved for drinking water applications.
- Suitable for low temperature hot water and chilled systems.

1210 Quarter Turn Ball Valve PN40 - (brass chrome plated) - red lever

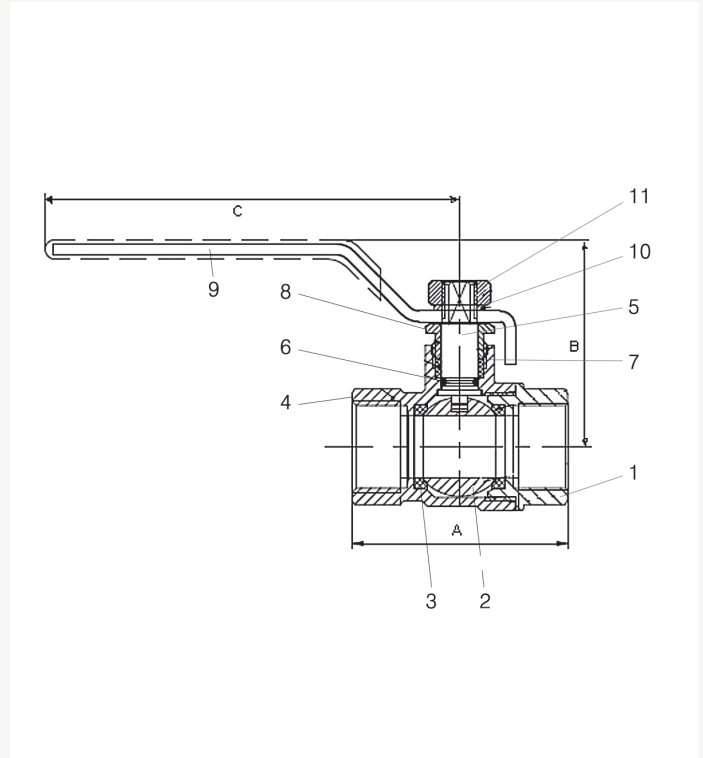

Material specification

1210 Lever handle version 1/2" to 2"			
No	Component	Material	Specification
1	End connector	Brass - chrome plate	EN 12165 CW617N-DW
2	Ball	Brass - chrome plate	EN 12165 CW617N-DW
3	Ball seal	PTFE	PTFE
4	Body	Brass - chrome plate	EN 12165 CW617N-DW
5	Stem	Brass	EN 12164 CW617N-DW
6	Stem O-ring	EPDM	EN 2430: 1995
7	Gland	PTFE	PTFE
8	Packing nut	Brass	EN 12164 CW617N-DW
9	Lever handle	Steel	EN 24T + polyethylene HD
10	Washer	Stainless steel	ISO 15510
11	Lever nut	Stainless steel	ISO 15510

Features and benefits:

- Full bore quarter turn ball valve.
- Blow out proof stem.
- End connections, female taper threads to EN 10226-2 (ISO 7-1) and parallel threads to ISO 228.
- WRAS approved for drinking water applications.
- Unique Conex Bänninger lever handle.

1210 Ball Valve									
Order code EN 10226-2 (ISO 7-1) thread	Order code ISO 228 thread	Size	DN	A	B	C	Kv value	Weight (kg)	
121013RRR400404	121010FFR400404	1/2"	15	55	48	95	16	0.226	
121013RRR400606	121010FFR400606	3/4"	20	65	52	95	30	0.400	
121013RRR400808	121010FFR400808	1"	25	78	65	130	48	0.648	
121013RRR401010	121010FFR401010	1.1/4"	32	91	69	130	100	0.976	
121013RRR401212	121010FFR401212	1.1/2"	40	99	80	160	170	1.430	
121010RRR401616	121010FFR401616	2"	50	119	88	160	230	2.450	

Valve suitability

Product	Steam	Water	Drinking water	Oil	Air (oil free)	Gas (inert)	Gas (combustible)	Gas (corrosive)	Gas (oxygen)
1210	x	✓	✓	✓	✓	x	x	x	x

This valve is not suitable for gas applications.

Max. working parameters

1210	Temperature °C	Pressure bar	Pressure psi
Water	-10 to +120	40	580

Specification clauses:

- Lever operated quarter turn, tight shut-off.
- Brass body, stem and cap.
- Chrome plated brass ball, body and end connectors.
- PTFE seats and stem gland seal.
- EPDM stem O-ring.
- End connections, female taper threads to EN 10226-2 (ISO 7-1) and parallel threads to ISO 228.
- WRAS approved for drinking water applications.

1215 Quarter Turn Ball Valve PN40 - (brass chrome plated) - red tee

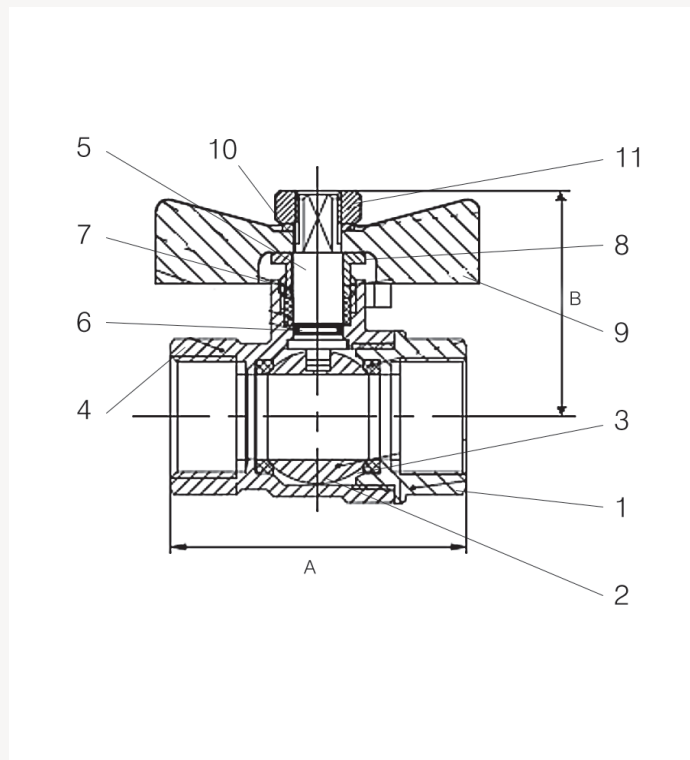

Material specification

1215 Tee handle version 1/2" to 1"			
No	Component	Material	Specification
1	End connector	Brass - chrome plate	EN 12165 CW617N-DW
2	Ball	Brass - chrome plate	EN 12165 CW617N-DW
3	Ball seal	PTFE	PTFE
4	Body	Brass - chrome plate	EN 12165 CW617N-DW
5	Stem	Brass	EN 12164 CW617N-DW
6	Stem O-ring	EPDM	EN 2430: 1995
7	Gland	PTFE	PTFE
8	Packing nut	Brass	EN 12164 CW617N-DW
9	Tee handle	Aluminium	EN 1706 LM6
10	Washer	Stainless steel	ISO 15510
11	Lever nut	Stainless steel	ISO 15510

Features and benefits:

- Full bore quarter turn ball valve.
- Blow out proof stem.
- End connections, female taper threads to EN 10226-2 (ISO 7-1) and parallel threads to ISO 228.
- WRAS approved for drinking water applications.

1215 Ball Valve

Order code EN 10226-2 (ISO 7-1) thread	Order code ISO 228 thread	Size	DN	A	B	Kv value	Weight (kg)
121513RRT400404	121513FFT400404	1/2"	15	55	38	16	0.226
121513RRT400606	121513FFT400606	3/4"	20	65	42	30	0.400
121513RRT400808	121513FFT400808	1"	25	78	50	48	0.648

Valve suitability

Product	Steam	Water	Drinking water	Oil	Air (oil free)	Gas (inert)	Gas (combustible)	Gas (corrosive)	Gas (oxygen)
1215	x	✓	✓	✓	✓	x	x	x	x

This valve is not suitable for gas applications.

Max. working parameters

1215	Temperature °C	Pressure bar	Pressure psi
Water	-10 to +120	40	580

Specification clauses:

- Tee operated quarter turn, tight shut-off.
- Chrome plated brass ball, body and end connectors.
- Brass, stem.
- PTFE seats and stem gland seal.
- EPDM stem O-ring.
- End connections, female taper threads to EN 10226-2 (ISO 7-1) and parallel threads to ISO 228.
- WRAS approved for drinking water applications.

1220 Quarter Turn Ball Valve PN40 - (DZR) - red lever

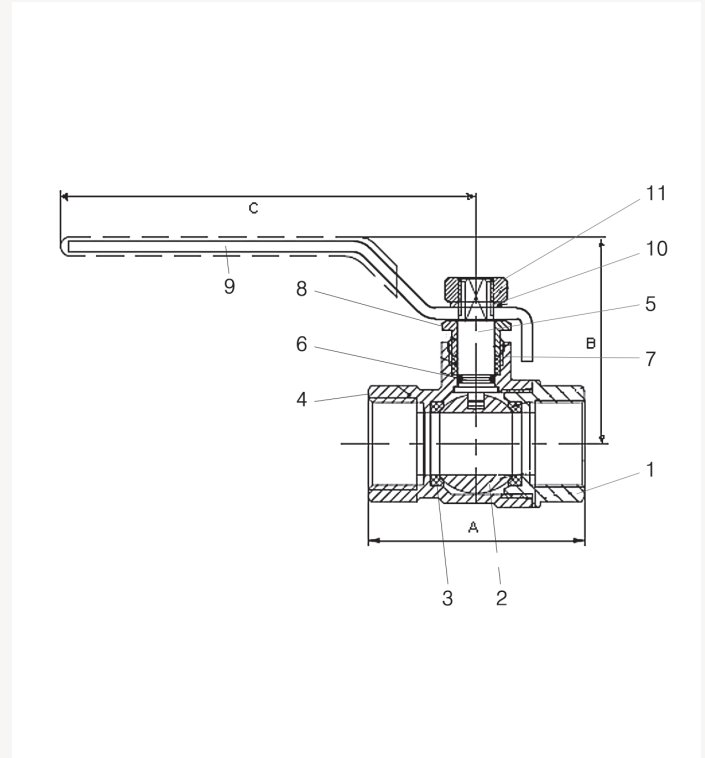

Material specification

1220 Lever handle version 1/2" to 2"

No	Component	Material	Specification
1	End connector	DZR brass	EN 12165 CW602N
2	Ball	Brass - chrome plate	EN 12165 CW617N-DW
3	Ball seal	PTFE	PTFE
4	Body	DZR brass	EN 12165 CW602N
5	Stem	DZR brass	EN 12164 CW602N
6	Stem O-ring	EPDM	EN 2430: 1995
7	Gland	PTFE	PTFE
8	Packing nut	Brass	EN 12164 CW617N-DW
9	Lever handle	Steel	EN 24T + polyethylene HD
10	Washer	Stainless steel	ISO 15510
11	Lever nut	Stainless steel	ISO 15510

Features and benefits:

- Full bore quarter turn ball valve.
- Blow out proof stem.
- Full DZR construction.
- End connections, female taper threads to EN 10226-2 (ISO 7-1) and parallel threads to ISO 228.
- WRAS approved for drinking water applications.
- Suitable for low temperature hot water and chilled systems.
- Unique Conex Bänninger lever handle.

1220 Ball Valve

Order code EN 10226-2 (ISO 7-1) thread	Order code ISO 228 thread	Size	DN	A	B	C	Kv value	Weight (kg)
122050RRR400404	122050FFR400404	1/2"	15	55	48	95	16	0.226
122050RRR400606	122050FFR400606	3/4"	20	65	52	95	30	0.360
122050RRR400808	122050FFR400808	1"	25	78	65	130	48	0.648
122050RRR401010	122050FFR401010	1.1/4"	32	91	69	130	100	0.976
122050RRR401212	122050FFR401212	1.1/2"	40	99	80	160	170	1.430
122050RRR401616	122050FFR401616	2"	50	119	88	160	230	2.050

Valve suitability

Product	Steam	Water	Drinking water	Oil	Air (oil free)	Gas (inert)	Gas (combustible)	Gas (corrosive)	Gas (oxygen)
1220	x	✓	✓	✓	✓	x	x	x	x

This valve is not suitable for gas applications.

Max. working parameters

1220	Temperature °C	Pressure bar	Pressure psi
Water	-10 to +120	40	580

Specification clauses:

- Lever operated quarter turn, tight shut-off.
- DZR brass body, stem and cap.
- Chrome plated brass ball.
- PTFE seats and stem gland seal.
- EPDM stem O-ring.
- End connections, taper threads to EN 10226-2 (ISO 7-1) and parallel threads to ISO 228.
- WRAS approved for drinking water applications.
- Suitable for low temperature hot water and chilled systems.

1225 Quarter Turn Ball Valve PN40 (DZR) red tee

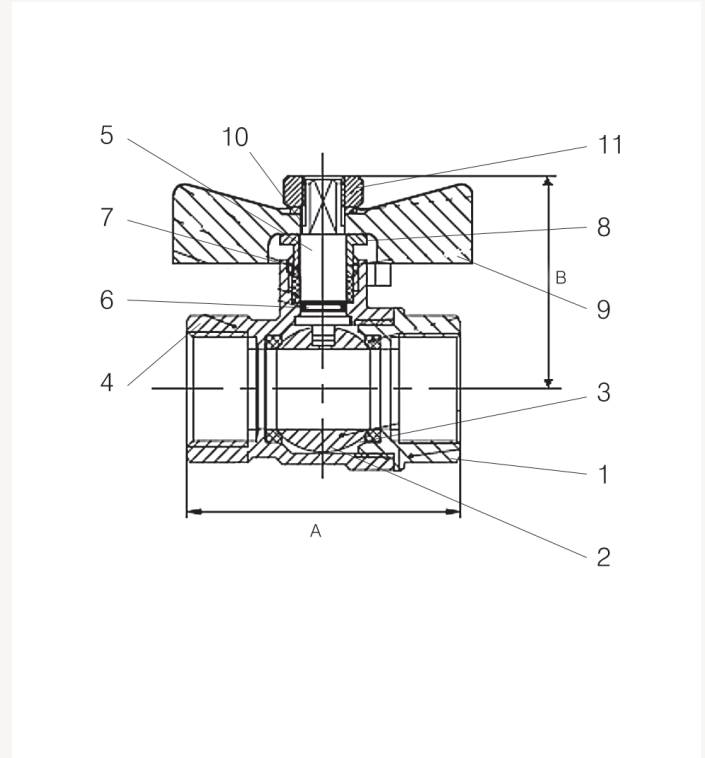

Material specification

1225 Tee handle version 1/2" to 1"

No	Component	Material	Specification
1	End connector	DZR brass	EN 12165 CW602N
2	Ball	Brass - chrome plate	EN 12165 CW617N-DW
3	Ball seal	PTFE	PTFE
4	Body	DZR brass	EN 12165 CW602N
5	Stem	DZR brass	EN 12164 CW602N
6	Stem O-ring	EPDM	EN 2430: 1995
7	Gland	PTFE	PTFE
8	Packing nut	Brass	EN 12164 CW617N-DW
9	Tee handle	Aluminium	EN 1706 LM6
10	Washer	Stainless steel	ISO 15510
11	Lever nut	Stainless steel	ISO 15510

Features and benefits:

- Full bore quarter turn ball valve.
- Blow out proof stem.
- Full DZR construction.
- End connections, female taper threads to EN 10226-2 (ISO 7-1) and parallel to ISO 228.
- WRAS approved for drinking water applications.
- Suitable for low temperature hot water and chilled systems.

1225 Ball valve

Order code EN 10226-2 (ISO 7-1) thread	Order code ISO 228 thread	Size	DN	A	B	Kv value	Weight (kg)
122550RRT400404	122550FFT400404	1/2"	15	55	38	16	0.210
122550RRT400606	122550FFT400606	3/4"	20	65	42	30	0.342
122550RRT400808	122550FFT400808	1"	25	78	50	48	0.648

Valve suitability

Product	Steam	Water	Drinking water	Oil	Air (oil free)	Gas (inert)	Gas (combustible)	Gas (corrosive)	Gas (oxygen)
1225	x	✓	✓	✓	✓	x	x	x	x

This valve is not suitable for gas applications.

Max. working parameters

1225	Temperature °C	Pressure bar	Pressure psi
Water	-10 to +120	40	580

Specification clauses:

- Tee operated quarter turn, tight shut-off.
- DZR brass body, stem and cap.
- Chrome plated brass ball.
- PTFE seats and stem gland seal.
- EPDM stem O-ring.
- End connections, female taper threads to EN 10226-2 (ISO 7-1) and parallel threads to ISO 228.
- WRAS approved for drinking water applications.
- Suitable for low temperature hot water and chilled water systems.

1230 Quarter Turn Ball Valve PN25 - (brass chrome plated) - red lever

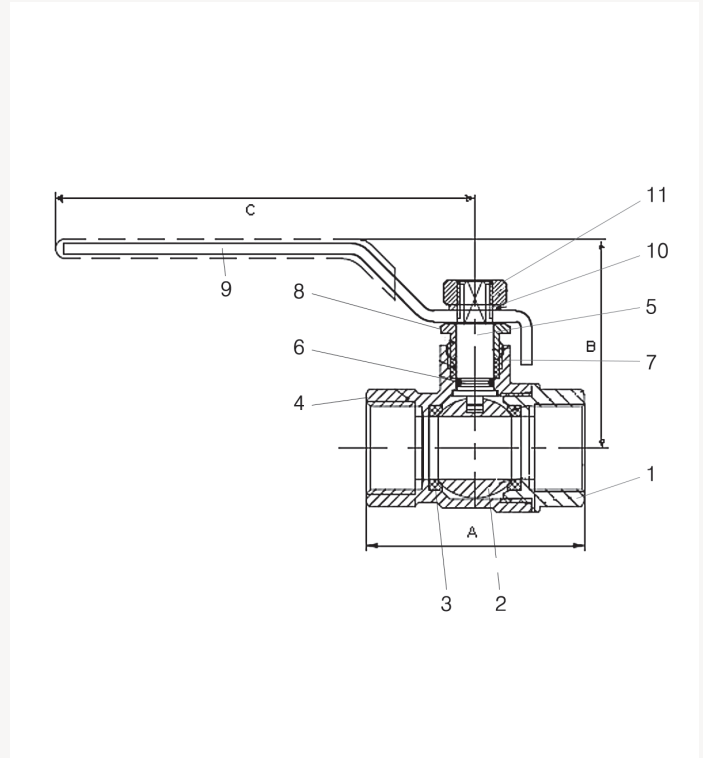

Material specification

1225 Tee handle version: 1/2" to 1"

No	Component	Material	Specification
1	End connector	Brass - chrome plate	EN 12165 CW617N-DW
2	Ball	Brass - chrome plate	EN 12165 CW617N-DW
3	Ball seal	PTFE	PTFE
4	Body	Brass - chrome plate	EN 12165 CW617N-DW
5	Stem	Brass	EN 12164 CW617N-DW
6	Stem O-ring	EPDM	EN 2430: 1995
7	Gland	PTFE	PTFE
8	Packing nut	Brass	EN 12164 CW617N-DW
9	Lever handle	Steel	EN 24T + polyethylene HD
10	Washer	Stainless steel	ISO 15510
11	Lever nut	Stainless steel	ISO 15510

Features and benefits:

- Full bore quarter turn ball valve.
- Blow out proof stem.
- End connections, female taper threads to EN 10226-2 (ISO 7-1) and parallel threads to ISO 228.
- Designed in accordance with WRAS requirements.
- Unique Conex Bänninger lever handle.

1230 Ball Valve									
Order code EN 10226-2 (ISO 7-1) thread	Order code ISO 228 thread	Size	DN	A	B	C	Kv value	Weight (kg)	
123013RRR250404	123013FFR250404	1/2"	15	55	48	95	16	0.207	
123013RRR250606	123013FFR250606	3/4"	20	65	52	95	30	0.333	
123013RRR250808	123013FFR250808	1"	25	78	65	130	48	0.602	
123013RRR251010	123013FFR251010	1.1/4"	32	91	69	130	100	0.927	
123013RRR251212	123013FFR251212	1.1/2"	40	99	80	160	170	1.369	
123013RRR251616	123013FFR251616	2"	50	119	88	160	230	2.225	

Valve suitability

Product	Steam	Water	Drinking water	Oil	Air (oil free)	Gas (inert)	Gas (combustible)	Gas (corrosive)	Gas (oxygen)
1230	x	✓	✓	✓	✓	x	x	x	x

This valve is not suitable for gas applications.

Max. working parameters

1230	Temperature °C	Pressure bar	Pressure psi
Water	-10 to +120	25	360

Specification clauses:

- Lever operated quarter turn, tight shut-off.
- Chrome plated brass ball, body and end connectors.
- Brass body, stem and cap.
- PTFE seats and stem gland seal.
- EPDM stem O-ring.
- End connections, female taper threads to EN 10226-2 (ISO 7-1) and parallel threads to ISO 228.
- Designed in accordance with WRAS requirements.

1231 Quarter Turn Ball Valve M x F PN25 - (brass chrome plated) - red lever

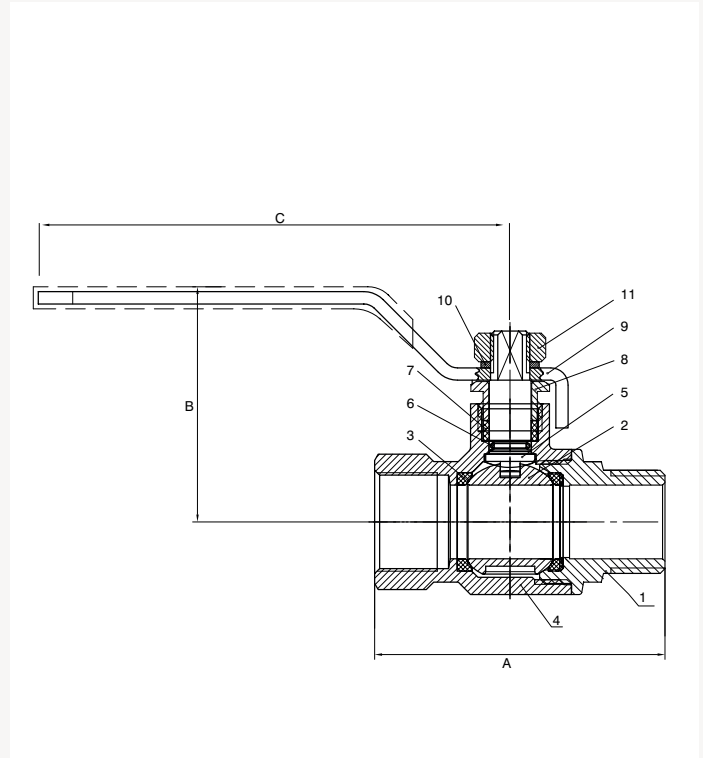

Material specification

1231 Lever handle version 1/2" to 2"			
No	Component	Material	Specification
1	End connector	Brass - chrome plate	EN 12165 CW617N-DW
2	Ball	Brass - chrome plate	EN 12165 CW617N-DW
3	Ball seal	PTFE	PTFE
4	Body	Brass - chrome plate	EN 12165 CW617N-DW
5	Stem	Brass	EN 12164 CW617N-DW
6	Stem O-ring	EPDM	EN 2430: 1995
7	Gland	PTFE	PTFE
8	Packing nut	Brass	EN 12164 CW617N-DW
9	Lever handle	Steel	EN 24T + polyethylene HD
10	Washer	Stainless steel	ISO 15510
11	Lever nut	Stainless steel	ISO 15510

Features and benefits:

- Full bore quarter turn ball valve.
- Blow out proof stem.
- Male x female end connections, taper threads to EN 10226-2 (ISO 7-1).
- Designed in accordance with WRAS requirements.
- Unique Conex Bänninger lever handle.

1231 Ball Valve

Order code EN 10226-2 (ISO 7-1) thread	Size	DN	A	B	C	Kv value	Weight (kg)
123113TRR250404	1/2"	15	55	48	95	16	0.208
123113TRR250606	3/4"	20	65	52	95	30	0.312
123113TRR250808	1"	25	78	65	130	48	0.602
123113TRR251010	1.1/4"	32	91	69	130	100	0.924
123113TRR251212	1.1/2"	40	99	80	160	170	1.362
123113TRR251616	2"	50	119	88	160	230	2.224

Valve suitability

Product	Steam	Water	Drinking water	Oil	Air (oil free)	Gas (inert)	Gas (combustible)	Gas (corrosive)	Gas (oxygen)
1231	x	✓	✓	✓	✓	x	x	x	x

This valve is not suitable for gas applications.

Max. working parameters

1231	Temperature °C	Pressure bar	Pressure psi
Water	-10 to +120	25	360

Specification clauses:

- Lever operated quarter turn, tight shut-off.
- Chrome plated brass ball, body and end connectors.
- Brass stem.
- PTFE seats and stem gland seal.
- EPDM stem O-ring.
- Male x female end connections, female taper threads to EN 10226-2 (ISO 7-1).
- Designed in accordance with WRAS requirements.

1232 Quarter Turn Ball Valve M x M PN25 - (brass chrome plated) - red lever

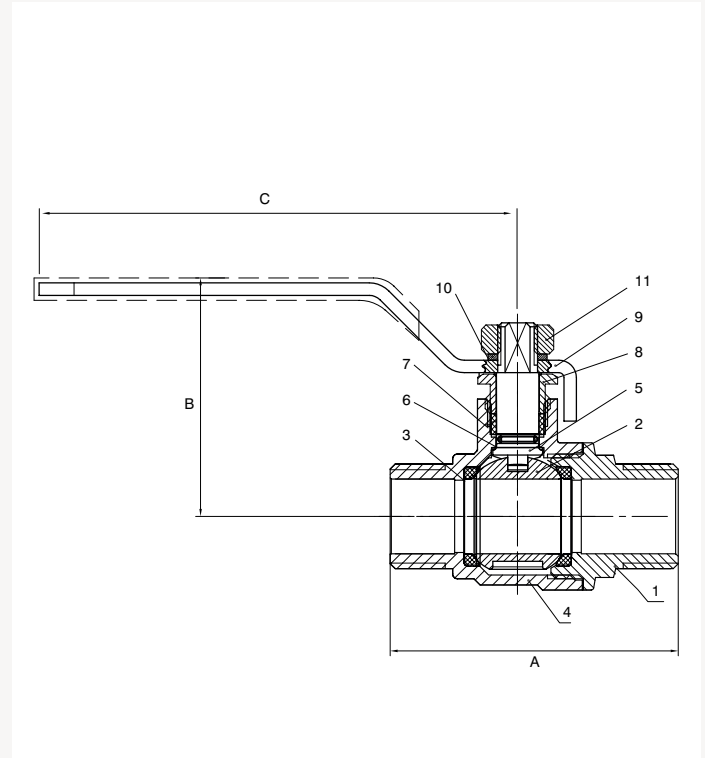

Material specification

1232 Lever handle version 1/2" to 2"

No	Component	Material	Specification
1	End connector	Brass - chrome plate	EN 12165 CW617N-DW
2	Ball	Brass - chrome plate	EN 12165 CW617N-DW
3	Ball seal	PTFE	PTFE
4	Body	Brass - chrome plate	EN 12165 CW617N-DW
5	Stem	Brass	EN 12164 CW617N-DW
6	Stem O-ring	EPDM	EN 2430: 1995
7	Gland	PTFE	PTFE
8	Packing nut	Brass	EN 12164 CW617N-DW
9	Lever handle	Steel	EN 24T + polyethylene HD
10	Washer	Stainless steel	ISO 15510
11	Lever nut	Stainless steel	ISO 15510

Features and benefits:

- Full bore quarter turn ball valve.
- Blow out proof stem.
- End connections male x male, taper threads to EN 10226-2 (ISO 7-1).
- Designed in accordance with WRAS requirements.
- Unique Conex Bänninger lever handle.

1232 Ball Valve

Order code EN 10226-2 (ISO 7-1) thread	Size	DN	A	B	C	Kv value	Weight (kg)
123213TTR250404	1/2"	15	55	48	95	16	0.208
123213TTR250606	3/4"	20	65	52	95	30	0.312
123213TTR250808	1"	25	78	65	130	48	0.602
123213TTR251010	1.1/4"	32	91	69	130	100	0.924
123213TTR251212	1.1/2"	40	99	80	160	170	1.362
123213TTR251616	2"	50	119	88	160	230	2.224

Valve suitability

Product	Steam	Water	Drinking water	Oil	Air (oil free)	Gas (inert)	Gas (combustible)	Gas (corrosive)	Gas (oxygen)
1232	x	✓	✓	✓	✓	x	x	x	x

This valve is not suitable for gas applications.

Max. working parameters

1232	Temperature °C	Pressure bar	Pressure psi
Water	-10 to +120	25	360

Specification clauses:

- Lever operated quarter turn, tight shut-off.
- Brass stem.
- Chrome plated brass ball, body and end connectors.
- PTFE seats and stem gland seal.
- EPDM stem O-ring.
- End connections male x male, taper threads to EN 10226-2 (ISO 7-1).
- Designed in accordance with WRAS requirements.

1235 Quarter Turn Ball Valve PN25 - (brass chrome plated) - red tee

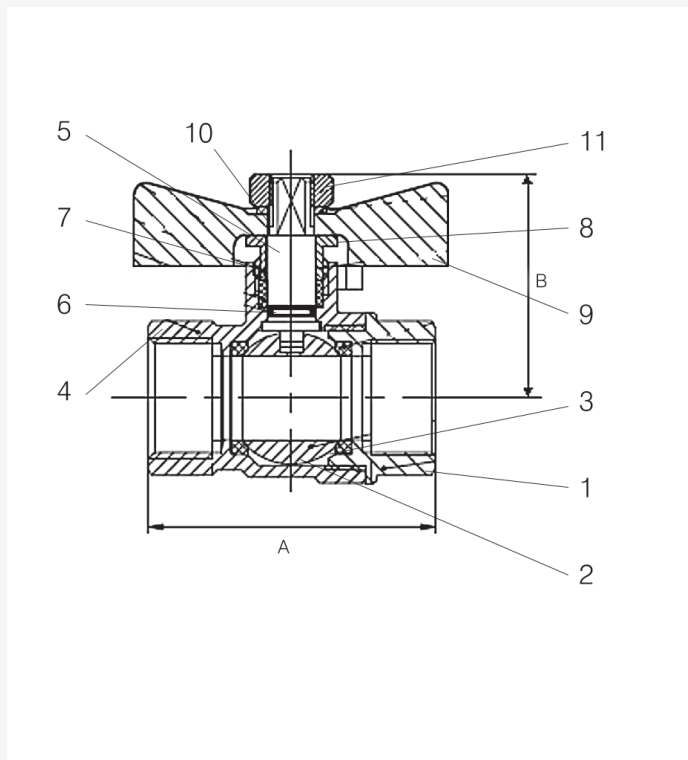

Material specification

1235 Tee handle version 1/2" to 1"			
No	Component	Material	Specification
1	End connector	Brass - chrome plate	EN 12165 CW617N-DW
2	Ball	Brass - chrome plate	EN 12165 CW617N-DW
3	Ball seal	PTFE	PTFE
4	Body	Brass - chrome plate	EN 12165 CW617N-DW
5	Stem	Brass	EN 12164CW617N-DW
6	Stem O-ring	EPDM	EN 2430: 1995
7	Gland	PTFE	PTFE
8	Packing nut	Brass	EN 12164 CW617N-DW
9	Tee handle	Aluminium	EN 1706 LM6
10	Washer	Stainless steel	ISO 15510
11	Lever nut	Stainless steel	ISO 15510

Features and benefits:

- Full bore quarter turn ball valve.
- Blow out proof stem.
- End connections, female taper threads to EN 10226-2 (ISO 7-1) and parallel threads to ISO 228.
- Designed in accordance with WRAS requirements.

1235 Ball Valve

Order code EN 10226-2 (ISO 7-1) thread	Order code ISO 228	Size	DN	A	B	Kv value	Weight (kg)
123513RRT250404	123513FFT250404	1/2"	15	55	38	16	0.208
123513RRT250606	123513FFT250606	3/4"	20	65	42	30	0.312
123513RRT250808	123513FFT250808	1"	25	78	50	48	0.602

Valve suitability

Product	Steam	Water	Drinking water	Oil	Air (oil free)	Gas (inert)	Gas (combustible)	Gas (corrosive)	Gas (oxygen)
1235	x	✓	✓	✓	✓	x	x	x	x

This valve is not suitable for gas applications.

Max. working parameters

1235	Temperature °C	Pressure bar	Pressure psi
Water	-10 to +120	25	360

Specification clauses:

- Tee operated quarter turn, tight shut-off.
- Brass stem.
- Chrome plated brass ball, body and end connector.
- PTFE seats and stem gland seal.
- EPDM stem O-ring.
- End connections, female taper threads to EN 10226-2 (ISO 7-1) and parallel threads to ISO 228.
- Designed in accordance with WRAS requirements.
- This valve is not suitable for gas applications.

1256 Quarter Turn Ball Valve PN16 - (DZR) - hose union drain tap

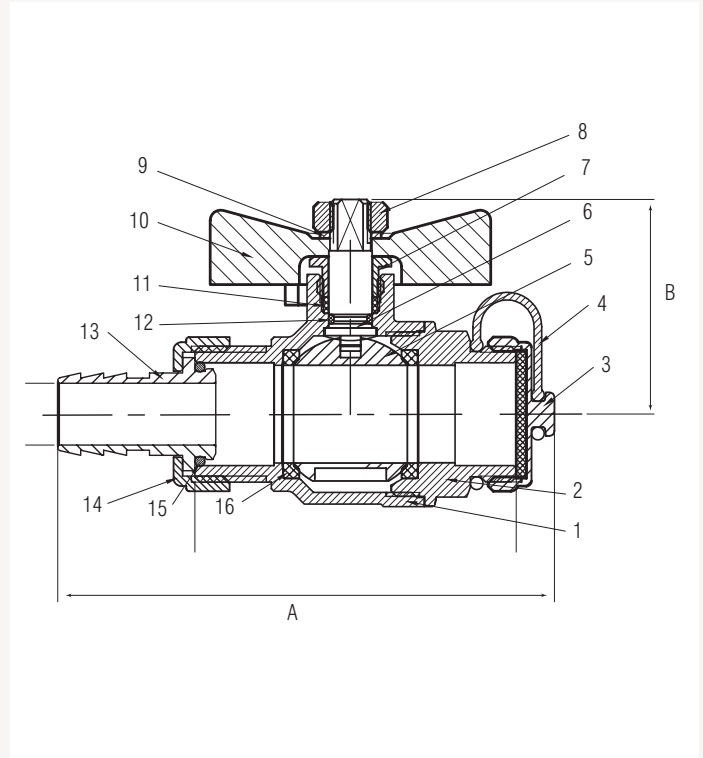

Material specification

1256 Tee handle version 1/2" to 3/4"			
No	Component	Material	Specification
1	Body	DZR brass	EN 12165 CW602N
2	End cap	DZR brass	EN 12165 CW602N
3	Dust cap	Brass	EN 12165 CW617N-DW
4	Retaining strap	EPDM	EN 2430: 1995
5	Ball	DZR brass	EN 12165 CW602N
6	Stem	DZR brass	EN 12164 CW602N
7	Stem nut	DZR brass	EN 12164 CW602N
8	Nut	Stainless steel	ISO 15510
9	Spring washer	Stainless steel	ISO 15510
10	Tee handle	Aluminium	EN 1706 LM6
11	Gland	PTFE	PTFE
12	O-ring	EPDM	EN 2430: 1995
13	Hose union	Brass	EN 12165 CW617N-DW
14	Retaining cap	Brass	EN 12165 CW617N-DW
15	O-ring	EPDM	EN 2430: 1995
16	Ball seat	PTFE	PTFE

Features and benefits:

- Full bore quarter turn ball valve.
- Full DZR construction.
- Blow out proof stem.
- End connections, male parallel threads to ISO 228.
- Supplied with hose union and dust cap.

1256 Ball valve

Order code ISO 228	Size	DN	A	B	Kv value	Weight (kg)
125650MHT160404	1/2"	15	93	38	16	0.252
125650MHT160606	3/4"	20	97	41	30	0.380

Valve suitability

Product	Steam	Water	Drinking water	Oil	Air (oil free)	Gas (inert)	Gas (combustible)	Gas (corrosive)	Gas (oxygen)
1256	x	✓	✓	✓	✓	x	x	x	x

This valve is not suitable for gas applications.

Max. working parameters

1256	Temperature °C	Pressure bar	Pressure psi
Water	-20 to +80	16	230

Specification clauses:

- Tee handle operated quarter turn, tight shut-off.
- DZR brass body stem and cap.
- Chrome plated brass ball.
- PTFE seats and stem seals.
- EPDM stem O-ring.
- End connections, male parallel threads to ISO 228.
- WRAS approved for drinking water applications.
- Suitable for low temperature hot water and chilled systems.
- Supplied with hose union and dust cap.

1260 Quarter Turn Ball Valve PN25 - (brass chrome plated) - red lever - short thread series

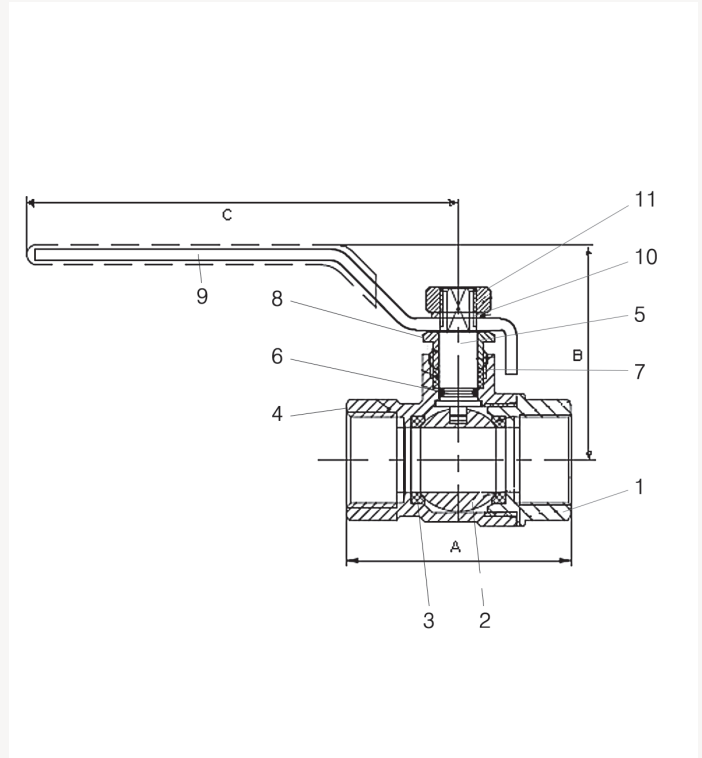

Material specification

1260 Lever handle version 1/2" to 2"

No	Component	Material	Specification
1	End connector	Brass - chrome plate	EN 12165 CW617N-DW
2	Ball	Brass - chrome plate	EN 12165 CW617N-DW
3	Ball seal	PTFE	PTFE
4	Body	Brass - chrome plate	EN 12165 CW617N-DW
5	Stem	Brass	EN 12164 CW617N-DW
6	Stem O-ring	EPDM	EN 2430: 1995
7	Gland	PTFE	PTFE
8	Packing nut	Brass	EN 12164 CW617N-DW
9	Lever handle	Steel + PVC	EN 24T + PVC
10	Washer	Stainless steel	ISO 15510
11	Lever nut	Stainless steel	ISO 15510

Features and benefits:

- Full bore quarter turn ball valve.
- Blow out proof stem.
- End connections, female taper threads to EN 10226-2 (ISO 7-1) and parallel threads to ISO 228.
- Short thread series allows minimum effective thread length for seal.
- WRAS approved for drinking water applications.
- Unique Conex Bänninger lever handle.

1260 Ball Valve									
Order code EN 10226-2 (ISO 7-1) thread	Order code ISO 228 thread	Size	DN	A	B	C	Kv value	Weight (kg)	
126013RRR250404	126013FFR250404	1/2"	15	50	48	95	16	0.186	
126013RRR250606	126013FFR250606	3/4"	20	58	52	95	30	0.264	
126013RRR250808	126013FFR250808	1"	25	69	65	130	48	0.462	
126013RRR251010	126013FFR251010	1.1/4"	32	81	69	130	100	0.614	
126013RRR251212	126013FFR251212	1.1/2"	40	89	80	160	170	0.938	
126013RRR251616	126013FFR251616	2"	50	110	88	160	230	1.450	

Valve suitability									
Product	Steam	Water	Drinking water	Oil	Air (oil free)	Gas (inert)	Gas (combustible)	Gas (corrosive)	Gas (oxygen)
1260	x	✓	✓	✓	✓	x	x	x	x

This valve is not suitable for gas applications.

Max. working parameters			
1260	Temperature °C	Pressure bar	Pressure psi
Water	-10 to +120	25	360

Specification clauses:

- Lever operated quarter turn, tight shut-off.
- Brass stem.
- Chrome plated brass ball, body and end connector.
- PTFE seats and stem gland seal.
- EPDM stem O-ring.
- End connections, female taper threads to EN 10226-2 (ISO 7-1) and parallel threads to ISO 228.
- WRAS approved for drinking water.

1265 Quarter Turn Ball Valve PN25 - (brass chrome plated) - red tee - short thread series

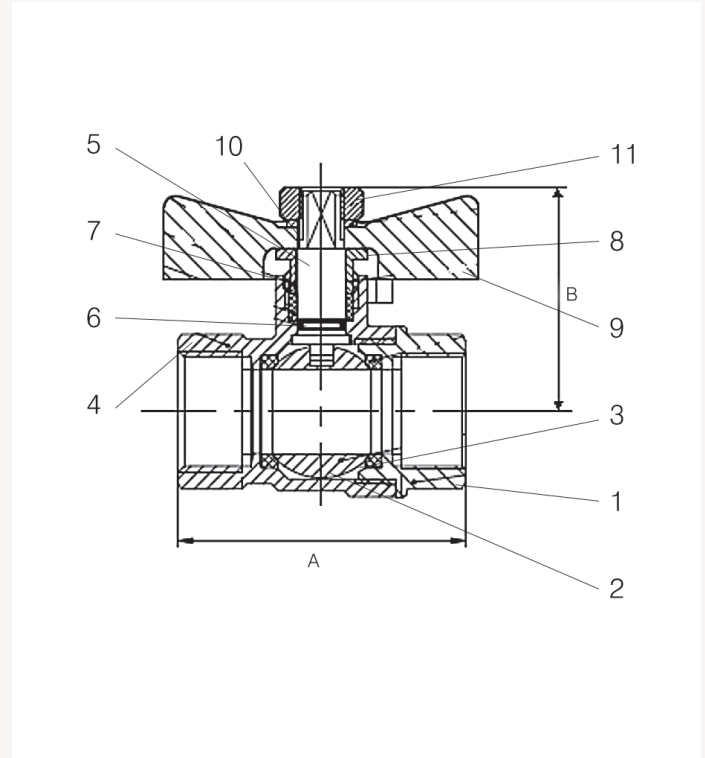

Material specification

1265 Tee handle version 1/2" to 1"			
No	Component	Material	Specification
1	End connector	Brass - chrome plate	EN 12165 CW617N-DW
2	Ball	Brass - chrome plate	EN 12165 CW617N-DW
3	Ball seal	PTFE	PTFE
4	Body	Brass - chrome plate	EN 12165 CW617N-DW
5	Stem	Brass	EN 12164 CW617N-DW
6	Stem O-ring	EPDM	EN 2430: 1995
7	Gland	PTFE	PTFE
8	Packing nut	Brass	EN 12164 CW617N-DW
9	Tee handle	Aluminium	EN 1706 LM6
10	Washer	Stainless steel	ISO 15510
11	Lever nut	Stainless steel	ISO 15510

Features and benefits:

- Full bore quarter turn ball valve.
- Blow out proof stem.
- End connections, female taper threads designed to EN 10226-2 (ISO 7-1) and parallel threads ISO 228.
- Short thread series allows minimum effective thread length for seal.
- WRAS approved for drinking water applications.

1265 Ball Valve

Order code EN 10226-2 (ISO 7-1) thread	Order code ISO 228 thread	Size	DN	A	B	Kv value	Weight (kg)
126513RRT250404	126513FFT250404	1/2"	15	50	38	16	0.162
126513RRT250606	126513FFT250606	3/4"	20	58	42	30	0.244
126513RRT250808	126513FFT250808	1"	25	69	50	48	0.420

Valve suitability

Product	Steam	Water	Drinking water	Oil	Air (oil free)	Gas (inert)	Gas (combustible)	Gas (corrosive)	Gas (oxygen)
1265	x	✓	✓	✓	✓	x	x	x	x

This valve is not suitable for gas applications.

Max. working parameters

1265	Temperature °C	Pressure bar	Pressure psi
Water	-10 to +120	25	360

Specification clauses:

- Tee operated quarter turn, tight shut-off.
- Chrome plated brass ball, body and end connector.
- Brass stem.
- PTFE seats and stem gland seal.
- EPDM stem O-ring.
- End connections, female taper threads designed to EN 10226-2 (ISO 7-1) and parallel threads to ISO 228.
- WRAS approved for drinking water applications.



8.0 Air Release Valves

Air release valves are designed to eliminate air trapped within the pipeline. Trapped air can lead to head loss, increased pumping cycles, increased energy consumption, equipment breakdown and water hammer.

Combination air release valves are the most commonly used valves. They perform the functions of an air/vacuum valve (exhaust large quantities of air on start-up, admit air on shut-down) and air release valves (release air continuously during operation).

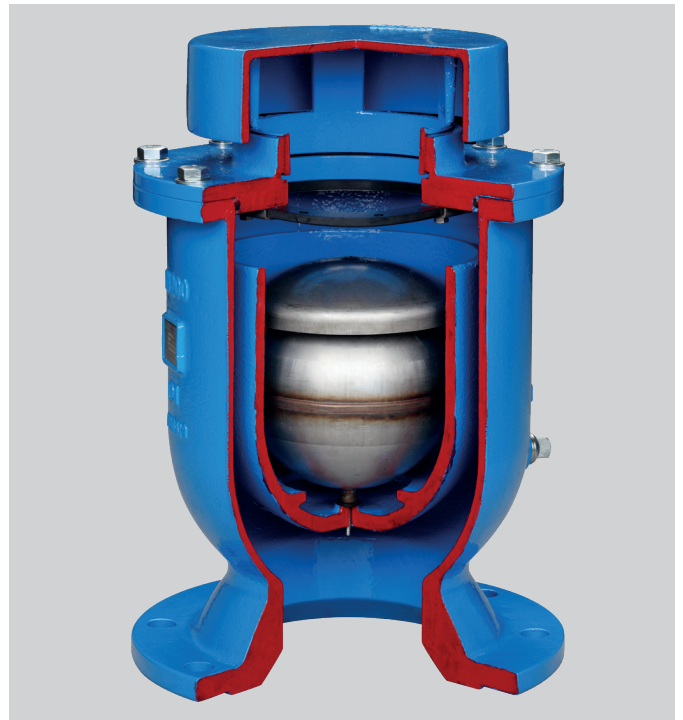

AVRX Combination Dual Orifice Air Release Valve PN16 flanged

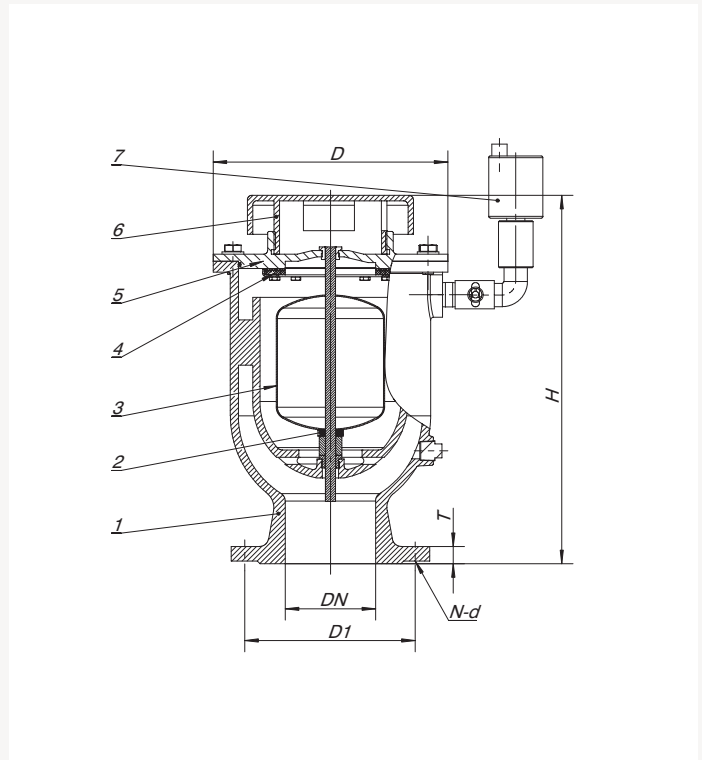

Material specification

AVRX Combination Dual Orifice Air Release Valve 2" to 8"

No	Component	Material
1	Body	Spheroidal graphite cast iron QT450-10
2	Gasket	Rubber EPDM
3	Ball	304 stainless steel / 316 stainless steel
4	Sealing ring	Rubber EPDM
5	Bonnet	Spheroidal graphite cast iron QT450-10
6	Cover	Spheroidal graphite cast iron QT450-10
7	Combination air valve	Ball valve + air valve

Technical data:

- Size: DN 50 - DN 200 (2" - 8").
- Nominal pressure: PN16.
- Temperature range: 0 °C to 80 °C.
- Flange standard: EN1092-2.
- Design standard: AWWA C512.
- Suitable for water.

Features and benefits:

- Combination air valves perform the functions of an air/vacuum valve (exhaust large quantities of air on start-up, admits air on shut-down) and air release valves (release air continuously during operation) to maintain system efficiency and prevent pipeline surges.
- Able to release air at high flow rates.
- No shut off due to negative pressure caused by high-speed airflow.
- No airtight phenomenon: minimum air pressure doesn't limit valves.
- High velocity air release close to sonic speed.
- The automatic air release function releases accumulated air from the system while it is under pressure.
- High sensitivity: when negative pressure occurs inside pipelines, valves rapidly open to inhale large volumes of air and protect the pipelines from damage.
- Floating ball and main disc are in stainless steel. This provides long service life, safety and reliability.
- Electrostatically coated with corrosion resistant epoxy powder internally and externally.

AVRX Combination Air Release Valve (mm)

Order code option 1	Order code option 2	Size	DN	H mm	D1 mm	T mm	N-d mm	D mm	Weight (kg)
A0050CFDMNMSSO	A0050CFDMNMSSU	2"	50	340	125	19	4-19	195	16.3
A0080CFDMNMSSO	A0080CFDMNMSSU	3"	80	340	160	19	8-19	195	19
A0100CFDMNMSSO	A0100CFDMNMSSU	4"	100	410	180	19	8-19	250	34.5
A0150CFDMNMSSO	A0150CFDMNMSSU	6"	150	485	240	19	8-23	330	48
A0200CFDMNMSSO	A0200CFDMNMSSU	8"	200	665	295	20	12-23	450	116.2

Option 1: AVRX - Ball 304 SS Option 2: AVRX - Ball 316 SS

Installation:

- The air release valve is suitable for installation at outlet of pump, or in water supply pipeline.
- Valves must be installed at the system high point in the vertical position with the inlet down.
- The pressure in system should not be less than 0.02Mpa. Otherwise the valve can't close.
- A shut off valve should be installed below the air release valve in case servicing is required.

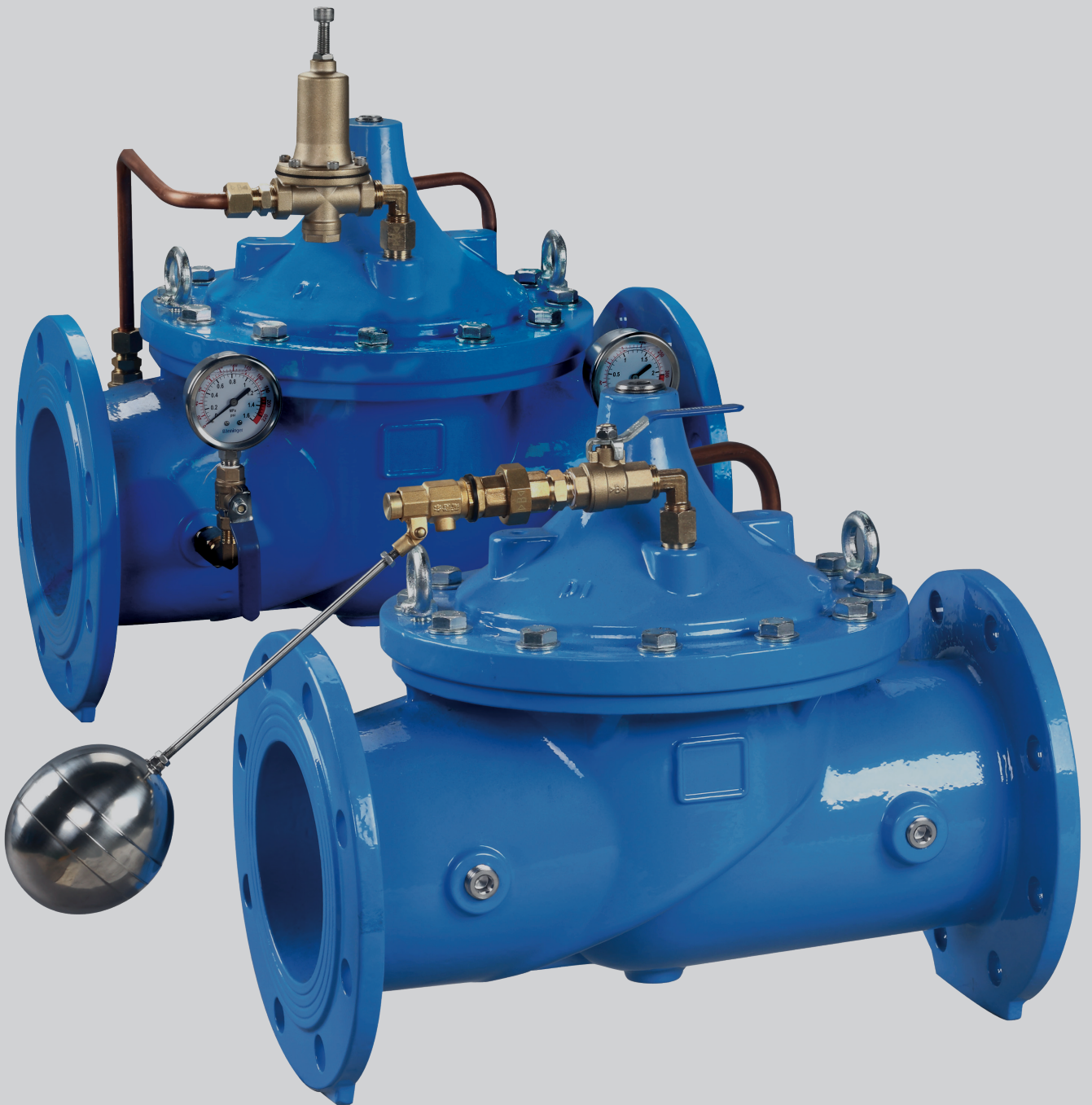

9.0 Automatic Control Valves

Conex Bänninger Floating Ball Liquid Level Control Valves are manufactured from high quality ductile iron and are electrostatically coated with corrosion resistant epoxy powder internally and externally. They provide automatic liquid level control of water (neutral liquids) in a tank.

Conex Bänninger Pressure Reducing Valves (PRVs) are manufactured from high quality ductile iron and are electrostatically coated with corrosion resistant epoxy powder internally and externally. Valves have corrosion resistant stainless steel or aluminium bronze seats depending on valve size. Conex Bänninger PRVs automatically reduce a higher inlet pressure to a steady lower downstream pressure, regardless of changing flow rate and / or varying inlet pressure.



A100 ACV Floating Ball Liquid Level Control Valve PN16 flanged

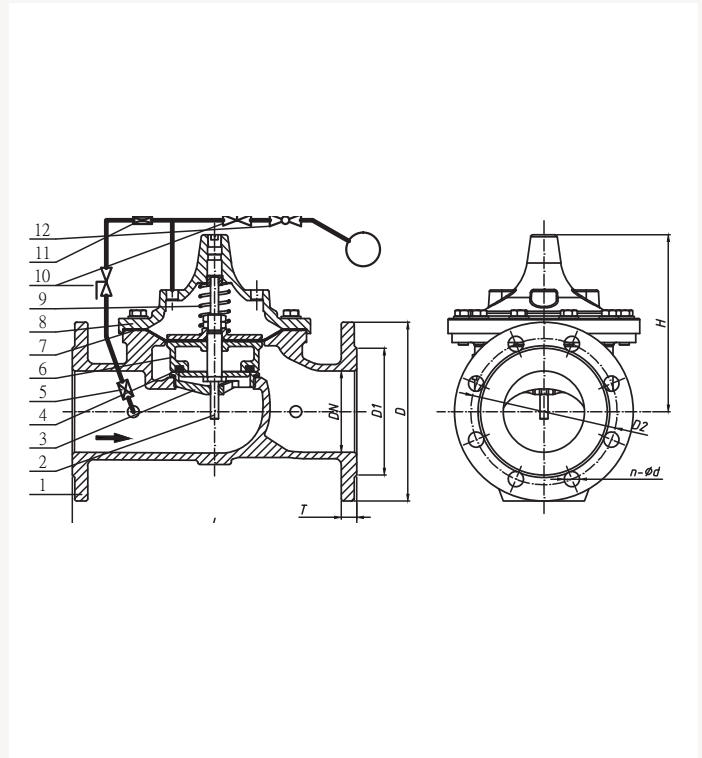

Material specification

A100 ACV Floating Ball Liquid Level Control Valve 2" to 8"

No	Component	Material
1	Body	Ductile iron GGG40
2	Guide bar	420 stainless steel
3	Seat	304 stainless steel
4	Seal ring	Rubber EPDM
5	Strainer	Composite member
6	Bracket	Ductile iron GGG40
7	Diaphragm	Rubber NBR
8	Bonnet	Ductile iron GGG40
9	Spring	304 stainless steel
10	Ball valve	Composite member
11	Pore plate	Brass
12	Float switch	Composite member

Applicable standards:

- Flange standard: EN 1092-2.
- Face to face standard: EN 558 Series 10.

Technical data:

- Size: DN 50 - DN 400 (2" - 16").
- Nominal pressure: PN16.
- Temperature range: 0 °C to 85 °C.
- Suitable for water and neutral liquids.

Features and benefits:

- Valve operates automatically.
- Single combined disc, for easy maintenance.
- Diaphragm type, fast response against pressure change.
- Large inner chamber, minimises cavitation noises and reduces static pressure.
- Easy to install, main body and floating ball can be installed separately.
- Manufactured from high quality ductile iron.
- Electrostatically coated with corrosion resistant epoxy powder internally and externally.

A100 ACV Series Floating Ball Liquid Level Control Valve dimensions

Order code	Size	DN	L mm	H mm	T mm	D mm	D1 mm	D2 mm	n-ød mm	Weight (kg)
F0050CFDMN01SO	2"	50	230	152	19	165	99	125	4-Ø19	12.5
F0065CFDMN01SO	2.1/2"	65	290	172	19	185	118	145	4-Ø19	16.5
F0080CFDMN01SO	3"	80	310	182	19	200	132	160	8-Ø19	20
F0100CFDMN01SO	4"	100	350	218	19	220	156	180	8-Ø19	30
F0125CFDMN01SO	5"	125	400	240	19	250	184	210	8-Ø19	41
F0150CFDMN01SO	6"	150	480	275	19	285	211	240	8-Ø23	56
F0200CFDMN01SO	8"	200	600	329	20	340	266	295	12-Ø23	101

Pressure drop curve (main valve fully open)

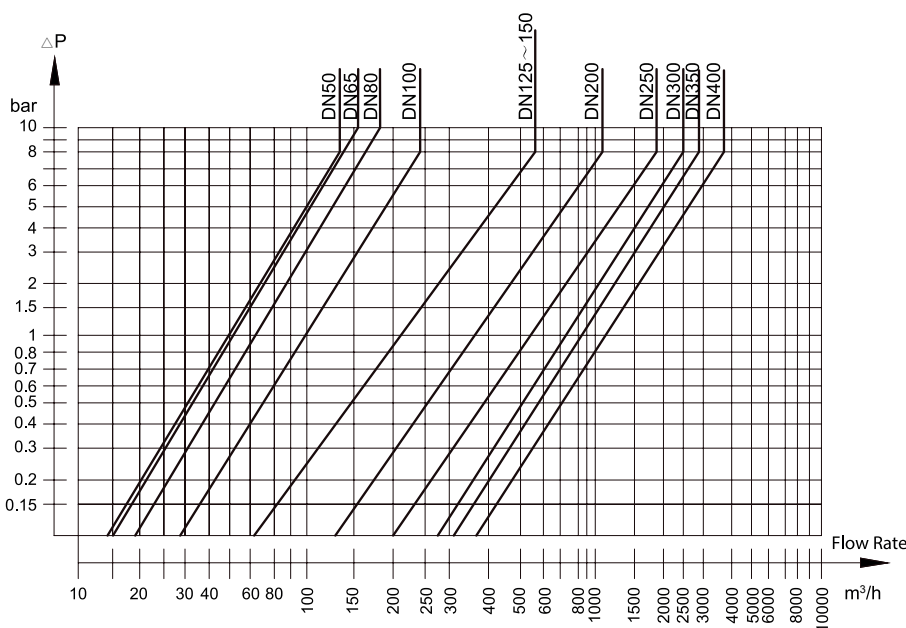

A200 ACV Pressure Reducing Valve PN16 flanged

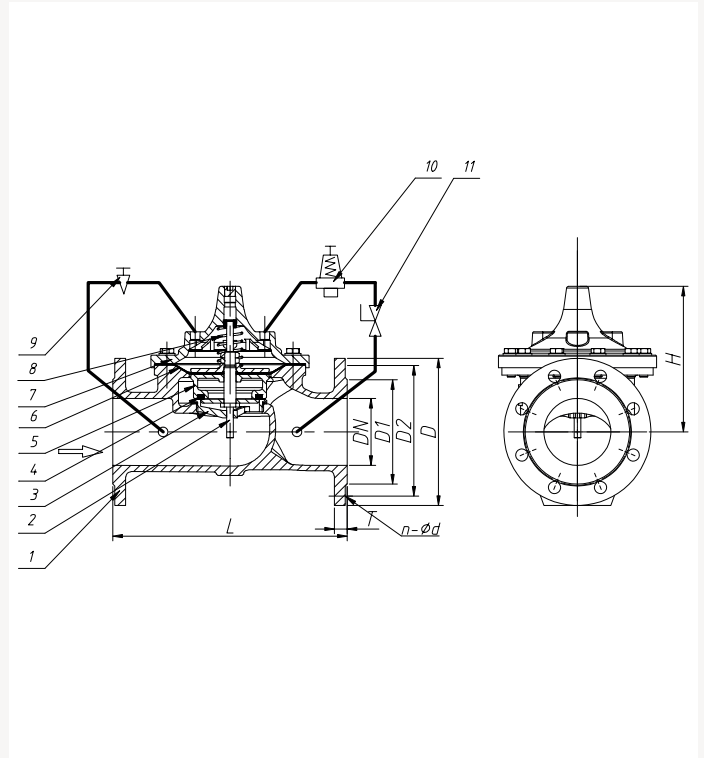

Material specification

A200 ACV Pressure Reducing Valve 2" to 16"

No	Component	Material
1	Body	Ductile iron GGG40
2	Stem	420 stainless steel
3	Seat	304 stainless steel
4	Seal	Rubber EPDM
5	Disc	Ductile iron GGG40
6	Diaphragm	Reinforced EPDM
7	Cover	Ductile iron GGG40
8	Spring	Spring steel 55CrSi
9	Needle valve	Brass
10	Guide valve	Brass
11	Ball valve	Brass

Applicable standards:

- Flange standard: EN 1092-2.
- Face to face standard: EN 558 Series 10.

Technical data:

- Size: DN 50 - DN 400 (2" - 16").
- Nominal pressure: PN16.
- Temperature range: -5 °C to 85 °C.
- Suitable for water and neutral liquids.

Features and benefits:

- Valve operates automatically.
- Single combined disc for easy maintenance.
- Diaphragm responds quickly to changes in pressure.
- Large inner chamber, minimises cavitation noise and reduces static pressure.
- Inlet pressure balancing function: Outlet pressure remains fixed interdependent of fluctuating inlet pressure.
- Manufactured from high quality ductile iron.
- Electrostatically coated with corrosion resistant epoxy powder internally and externally.
- Corrosion resistant stainless steel and bronze seats available.
- Long life reinforced nylon + EPDM diaphragm.

A200 ACV Series Pressure Reducing Valve dimensions

Order code	Size	DN	D mm	D1 mm	D2 mm	T mm	n-Ød mm	L mm	H mm	Weight (kg)
P0050CFDMN01SO	2"	50	165	99	125	19	4-19	230	152	14.0
P0065CFDMN01SO	2.1/2"	65	185	118	145	19	4-19	290	172	18.0
P0080CFDMN01SO	3"	80	200	132	160	19	8-19	310	182	21.5
P0100CFDMN01SO	4"	100	220	156	180	19	8-19	350	218	32.0
P0125CFDMN01SO	5"	125	250	184	210	19	8-19	400	240	42.0
P0150CFDMN01SO	6"	150	285	211	240	19	8-23	480	275	58.0
P0200CFDMN01SO	8"	200	340	266	295	20	12-23	600	329	103.0
P0250CFDMN01SO	10"	250	405	319	355	22	12-28	622	418	252.0
P0300CFDMN01SO	12"	300	460	370	410	25	12-28	698	503	317.0
P0350CFDMN01SO	14"	350	520	429	470	27	16-28	787	580	427.0
P0400CFDMN01SO	16"	400	580	480	525	28	16-31	914	639	554.0

Pressure drop curve (main valve fully open)

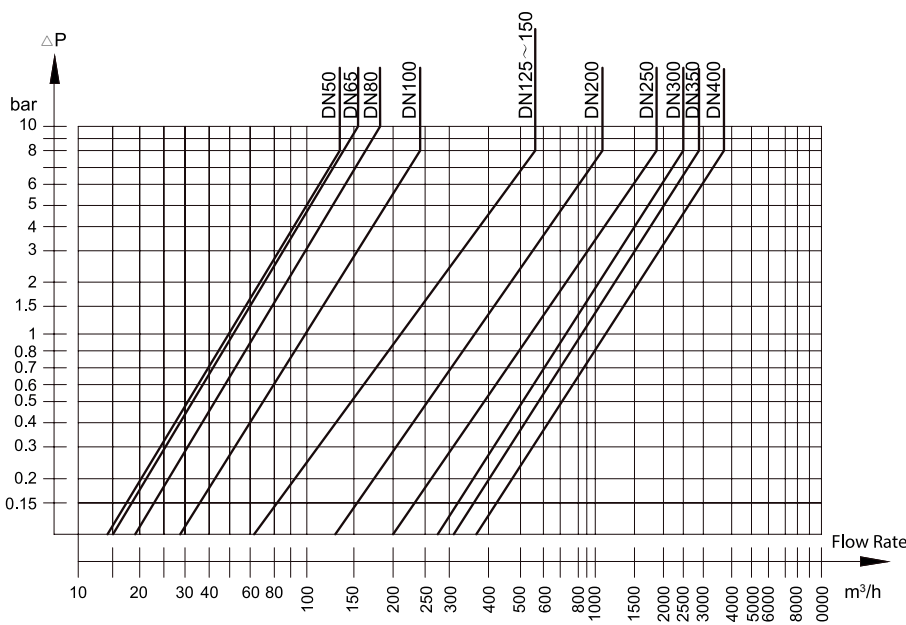



10.0 Rubber Flexible Connectors

Conex Bänninger Rubber Flexible Connectors are manufactured from high impact resistance EPDM rubber with nylon and stainless steel wire reinforcing and are able to bear high pressure flows in water pipelines. They protect the pipeline from thermal movements due to changes in temperature, pump vibration, resist surge pressures and alleviate the effects caused by water hammer, reduce noise and allow displacement compensation - minor misalignment in pipelines. They have been fatigue tested over one million cycles to ensure long service life.



S10 Rubber Flexible Joint PN16 flanged single ball type

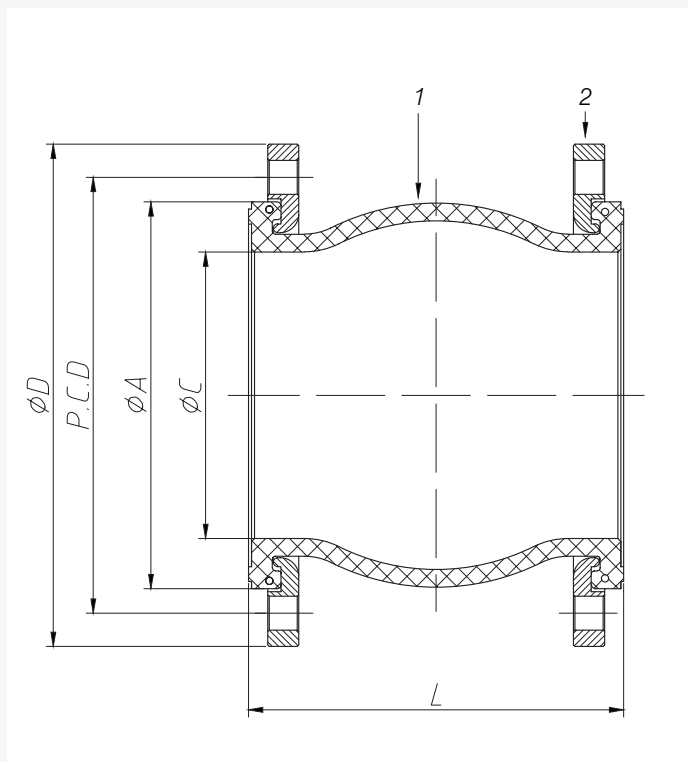

Material specification

S10 Rubber Flexible Joint 2" to 24"

No	Component	Material
1	Body	EPDM rubber reinforced with nylon and stainless steel wire
2	Flange	Carbon steel with zinc plating

S10 Rubber Flexible Joint dimensions

Order code	Size	DN	L mm	ϕA mm	ϕC mm	ϕD mm	PCD mm	n- ϕd mm
J0050CFMMNMSSO	2"	50	95	84	50	165	125	4- $\phi 18$
J0065CFMMNMSSO	2.1/2"	65	95	105	65	185	145	4- $\phi 18$
J0080CFMMNMSSO	3"	80	130	119	72	200	160	8- $\phi 18$
J0100CFMMNMSSO	4"	100	135	147	98	220	180	8- $\phi 18$
J0125CFMMNMSSO	5"	125	170	180	122	250	210	8- $\phi 18$
J0150CFMMNMSSO	6"	150	180	211	146	285	240	8- $\phi 22$
J0200CFMMNMSSO	8"	200	205	262	198	340	295	12- $\phi 22$
J0250CFMMNMSSO	10"	250	240	322	242	405	355	12- $\phi 26$
J0300CFMMNMSSO	12"	300	260	370	294	460	410	12- $\phi 26$
J0350CFMMNMSSO	14"	350	265	426	348	520	470	16- $\phi 26$
J0400CFMMNMSSO	16"	400	265	472	392	580	525	16- $\phi 30$
J0450CFMMNMSSO	18"	450	265	533	447	640	585	20- $\phi 30$
J0500CFMMNMSSO	20"	500	265	580	490	715	650	20- $\phi 33$
J0600CFMMNMSSO	24"	600	265	694	598	840	770	20- $\phi 37$

Applicable standards:

- Connection standard: GB/T17241.6-1998.
- Pressure test standard: GB/T13927.
- Face to face standard: IBP Standard.

Features and benefits:

- High impact resistance rubber reinforced with nylon wire and stainless steel wire, is able to bear high pressure flows without any influence on the product tensile strength.
- High reliability: Fatigue tested to ensure long life, 1,000,000 cycles.
- Flexible rubber connectors protect the pipeline from movement.

Technical data:

- Size: DN 50 - DN 600 (2" - 24").
- Nominal pressure: PN16.
- Temperature range: -5 °C to 85 °C.
- Suitable for water and sea water.
- Burst test pressure: 5.8 MPa (DN 50 - DN 200), 3.9 MPa (DN 250 - DN 600).

S10 Rubber Flexible Joint characteristics and technical parameters

Size	DN	L mm	Axial compression	Axial extension	Transverse deflection	Angular deflection	Max pressure	Max temperature °C	Vacuum level Torr (inHg)
2"	50	105	8	6	8	15°	10 (150)	+85 °C	660 (26.40)
2.1/2"	65	115	12	6	10	15°	10 (150)	+85 °C	660 (26.40)
3"	80	130	12	10	10	15°	10 (150)	+85 °C	660 (26.40)
4"	100	135	18	10	12	15°	10 (150)	+85 °C	660 (26.40)
5"	125	170	18	10	12	15°	10 (150)	+85 °C	660 (26.40)
6"	150	180	18	14	12	15°	10 (150)	+85 °C	660 (26.40)
8"	200	205	25	14	22	15°	10 (150)	+85 °C	660 (26.40)
10"	250	240	25	14	22	15°	10 (150)	+85 °C	660 (26.40)
12"	300	260	25	16	22	15°	10 (150)	+85 °C	660 (26.40)
14"	350	265	25	16	22	15°	7 (105)	+85 °C	660 (26.40)
16"	400	265	25	16	22	15°	7 (105)	+85 °C	660 (26.40)
18"	450	265	25	16	22	15°	7 (105)	+85 °C	660 (26.40)
20"	500	265	25	16	22	15°	7 (105)	+85 °C	660 (26.40)
24"	600	265	25	16	22	15°	7 (105)	+85 °C	660 (26.40)

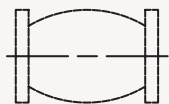

Normal position



Compression

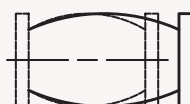

Elongation



Transverse movement



Angular movement

S20 Rubber Expansion Joint PN16 flange double sphere type

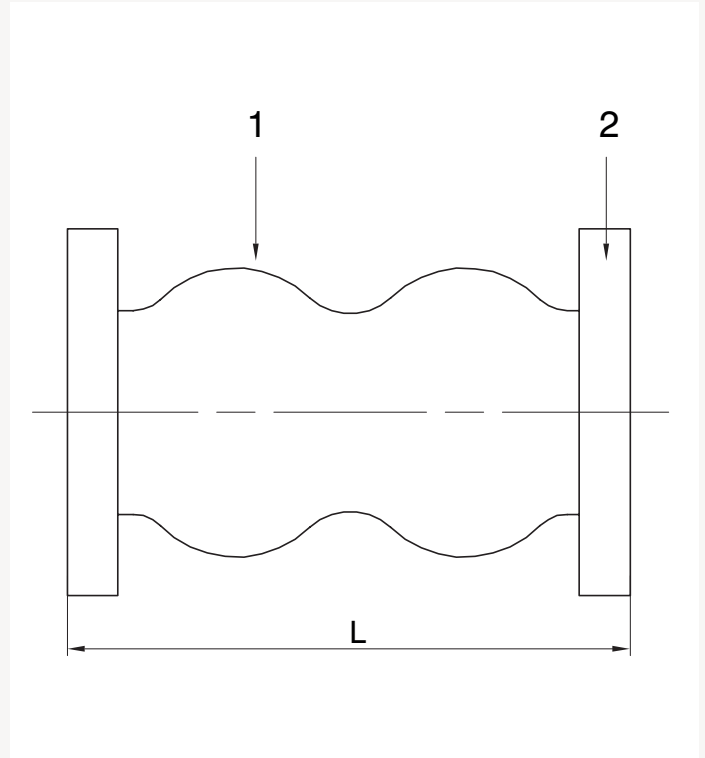

Material specification

S20 Rubber Expansion Joint 1 1/4" to 24"

No	Component	Material
1	Body	EPDM rubber reinforced with nylon and stainless steel wire
2	Flange	304 stainless steel

Rubber Flexible Connectors

Applicable standards:

- Connection standard: GB/T17241.6-1998.
- Pressure test standard: GB/T13927.
- Face to face standard: IBP Standard.

Features and benefits:

- High impact resistance rubber reinforced with nylon and stainless steel wire, is able to bear high pressure flows without any influence on the product tensile strength.
- High reliability: Fatigue tested to ensure long life, 1,000,000 cycles.
- Flexible rubber, to protect the pipeline from movement.

Technical data:

- Size: DN 25 - DN 600 (1" - 24").
- Nominal pressure: PN16.
- Temperature range: -5 °C to 85 °C.
- Vacuum degree: 250mm Hg.
- Burst pressure: 3 MPa.
- Suitable for water.
- Connection type: Flange connection.

S20 Double Sphere Rubber Expansion Joint dimensions and characteristics

Order Code	Size	DN	L	Axial compression	Axial extension	Transverse deflection	Angular deflection
E0032CFMMNMSSO	1.1/4"	32	175	50	30	35	40°
E0040CFMMNMSSO	1.1/2"	40	175	50	30	35	40°
E0050CFMMNMSSO	2"	50	175	50	30	35	40°
E0065CFMMNMSSO	2.1/2"	65	175	50	30	35	40°
E0080CFMMNMSSO	3"	80	175	50	30	35	40°
E0100CFMMNMSSO	4"	100	225	57	35	40	35°
E0125CFMMNMSSO	5"	125	225	57	35	40	35°
E0150CFMMNMSSO	6"	150	225	57	35	40	35°
E0200CFMMNMSSO	8"	200	325	63	35	45	30°
E0250CFMMNMSSO	10"	250	325	63	35	45	30°
E0300CFMMNMSSO	12"	300	325	63	35	45	30°
E0350CFMMNMSSO	14"	350	350	40	30	30	20°
E0400CFMMNMSSO	16"	400	350	40	30	30	20°
E0450CFMMNMSSO	18"	450	350	40	30	30	20°
E0500CFMMNMSSO	20"	500	350	40	30	30	20°
E0600CFMMNMSSO	24"	600	350	40	30	30	20°

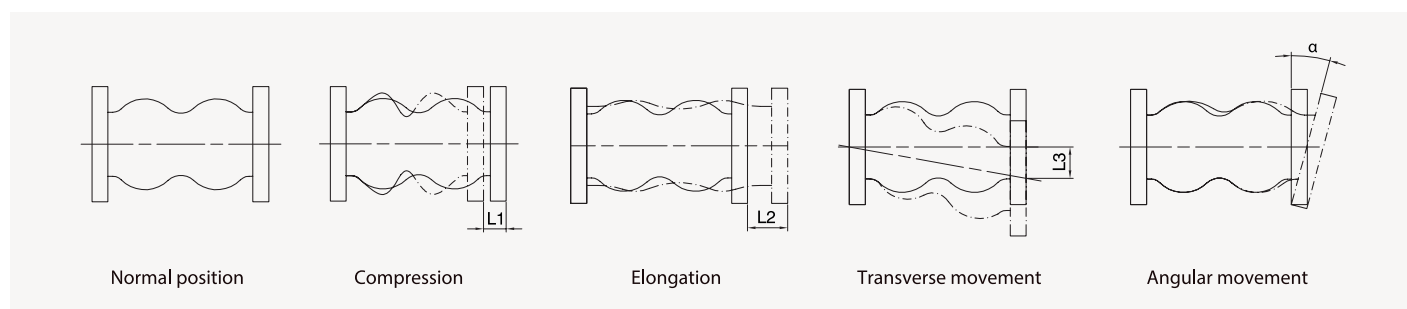



11.0 Pressure Independent Control Valve

Conex Bänninger Pressure Independent Control Valves are ideal for use in variable flow re-circulating pipeline systems. Each Conex Bänninger PICV replaces up to three separate valves i.e. regulating valve, two port control valve, plus a differential pressure control valve. They simplify selection and commissioning, reduce the number of valves, installation time and joints – potential leak points.

A Conex Bänninger PICV can be fitted in low temperature heating and chilled water systems to provide:

- Flow control – enabling modulating control of heating/cooling outputs.
- Flow regulation – enabling flow rates to be set at their specified design values.
- Differential pressure control – ensuring a constant differential pressure across control valves regardless of changes in pump speed or valve closures elsewhere in the system.



TBSX Pressure Independent Control Valve PN16 threaded connections

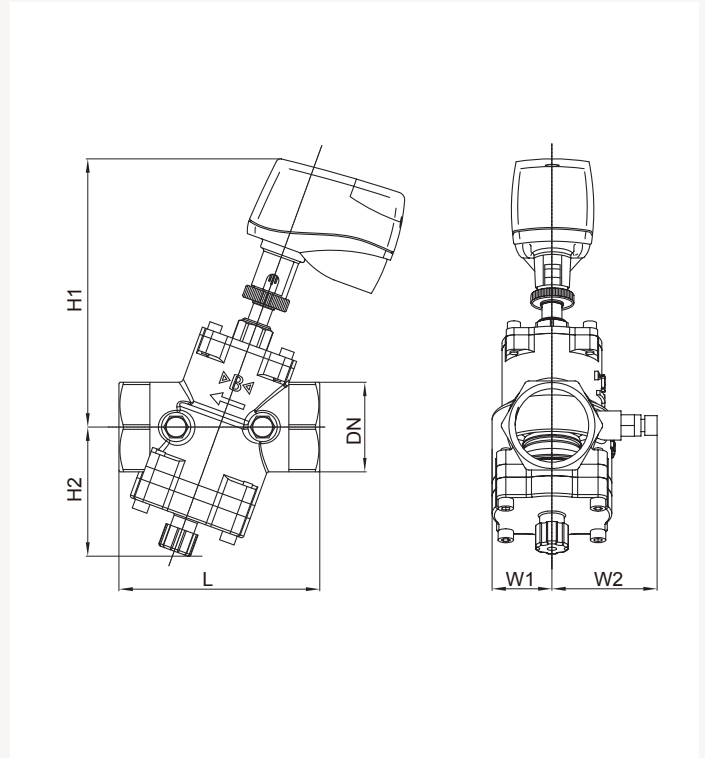

Material specification

TBSX Pressure Independent Control Valve 1 1/4" to 2"

No	Component	Material
1	Body	Bronze C83600
2	Bonnet	Brass C38000
3	Seat	304 stainless steel
4	Disc	304 stainless steel
5	Stem	304 stainless steel
6	Scale bar	Brass C38000
7	Adjusting nut	Brass C38000
8	Diaphragm	Rubber EPDM
9	Spring	304 stainless steel

Pressure Independent Control Valves

Applicable standards:

- Design standard: Q/IBP 1-0001-2014.
- Flange standard: GB/T 17241.6 EN 1092.
- Threaded standard:
EN 10226.1 - 10226.2.
- Face to face standard: GB/T 12221
EN 558-1.
- Pressure test standard: CJ/T 179.

Features and benefits:

- Three functions in one: automatic electronic adjustment + pressure independent control + static balancing.
- Linear flow control.
- Uses straight travel plug disc, lower torque.
- Adjustable Kvs allowing control of maximum flow rate.
- Wide differential pressure control range with precise flow control.
- Manufactured from high quality bronze.

Technical data:

- Nominal dimension: DN 32 - DN 150
(1.1/2" - 6").
- Nominal pressure: PN16.
- Work temperature: -5 °C to 85 °C.
- Shell test: 1.5 PN.
- Seat test: 1.1 PN.
- Suitable for water, ethylene glycol, etc.

Performance parameters

DN	Differential pressure range KPa	Minimum flow m ³ /h	Maximum flow m ³ /h	Valve stroke mm	Actuator model
DN32	30 - 400	0.6	4.5	5	MD50-R-BA Actuator
DN40	30 - 400	1.0	6.3	10	MD50-R-BA Actuator
DN50	30 - 400	1.5	12	10	MD50-R-BA Actuator

TBSX Series Pressure Independent Control Valve dimensions valve + actuator (mm)

Order code	Size	DN	L	H1	H2	W1	W2	Weight(Kg)
I0032CTBGMMSSO	1.1/4"	32	130	72	98	39	72	3.5
I0040CTBGMMSSO	1.1/2"	40	130	72	97	39	72	4.1
I0050CTBGMMSSO	2"	50	150	89	107	47	72	5.9

MD50-R-BA Actuator

Technical data:

- Voltage: 24 V AC.
- Power: 2 VA.
- Closing torque: 500 N.
- Maximum stroke: 10 mm.
- Input signal:
0(2) - 10 V, 0(4) - 20 mA.
- Feedback signal: 0 - 10 V.
- Work temperature: 0 °C to 50 °C.
- Protection grade: IP40.

Features and benefits:

- Multiple input and output signal selection options, allowing fast simple system configuration.
- Self calibration, actuator accurately calibrates stroke length.
- Block protection prevents the valve from sticking if it has not moved for a long period of time.
- Safe mode: the actuator will power off automatically once the actuator has fully opened.

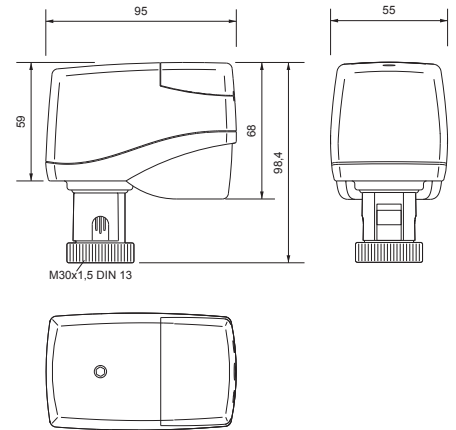

Operating instruction

Manual operation / power failure.

Manual adjustment / operation of the actuator may be performed after the actuator has been installed but only when it is disconnected from the mains supply.

A 4mm allen key can be used (see above) to adjust operating position of the actuator e.g. On / Off.

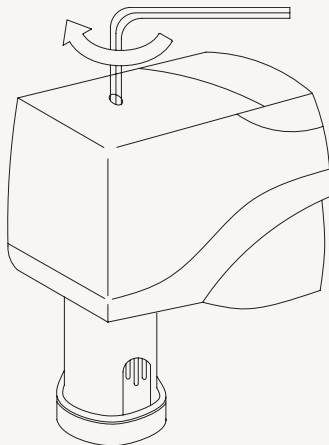

Conversion of the input signal

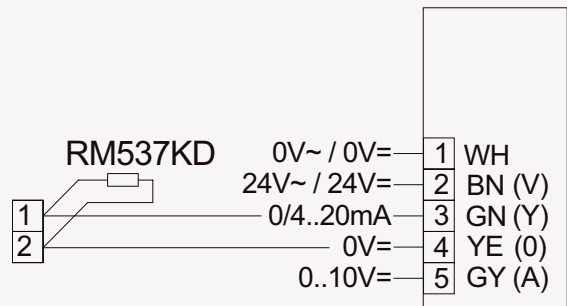

Input signal selection: 0(2) - 10 V or 0(4) - 20 mA

To change the input signal from 0(2) - 10 V to 0(4) - 20 mA bridge terminals 1 and 2 with resistance (RM537KD).

Function switch

Function	Switch (A)	Function
No function	<input type="checkbox"/> 6	No function
Switching position auxiliary switch active	<input type="checkbox"/> 5	Switching position auxiliary switch inactive
Characteristic curve compensation on	<input type="checkbox"/> 4	Characteristic curve compensation off
Actuation direction and positioning feedback 100% to 0%	<input type="checkbox"/> 3	Actuation direction and positioning feedback 0% to 100%
DC: 2 V to 10 V	<input type="checkbox"/> 2	DC: 0 to 10 V
Valve block protection on	<input type="checkbox"/> 1	Valve block protection off

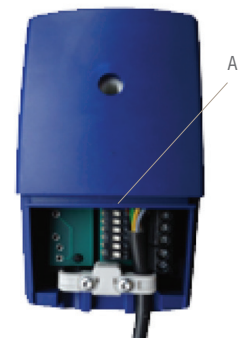

The valve functions are adjusted with switch A by placing the dip switches 1 to 6 in the desired position. The switch is located under the wiring connection cover.

TBFX Pressure Independence Control Valve PN16 Flanged

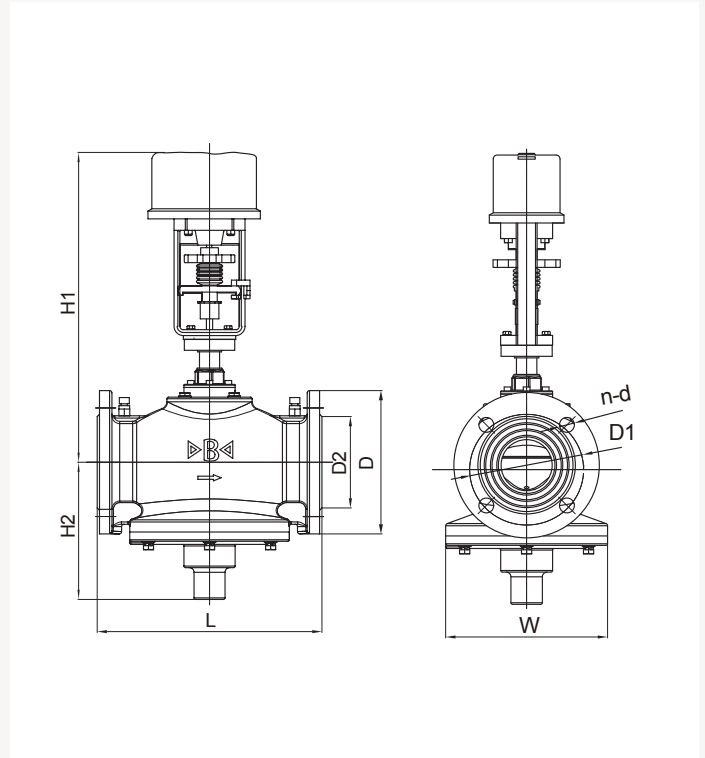

Material specification

TBFX Series Pressure Independence Control Valve 2 1/2" to 6"

No	Component	Material
1	Body	Ductile iron JS1040
2	Bonnet	Ductile iron JS1040
3	Seat	304 stainless steel
4	Disc	304 stainless steel
5	Stem	304 stainless steel
6	Scale bar	Brass C38000
7	Adjusting nut	Brass C38000
8	Diaphragm assembly	EPDM and 304 stainless steel
9	Spring	304 stainless steel

TBFX Pressure Independence Control Valve PN16 Flanged

Applicable standards:

- Design standard: Q/IBP 1-0001-2014.
- Flange standard: GB/T 17241.6 EN 1092.
- Threaded standard:
EN 10226.1 - 10226.2.
- Face to face standard: GB/T 12221
EN 558-1.
- Pressure test standard: CJ/T 179.

Features and benefits:

- Three functions in one: automatic electronic adjustment + pressure independent control + static balancing.
- Linear flow control.
- Uses straight travel plug disc, lower torque.
- Adjustable KVS allowing control of maximum flow rate.
- Wide differential pressure control range with precise flow control.
- Manufactured from high quality ductile iron.

Technical data:

- Nominal dimension:
DN 32 - DN 150 (1.1/2" - 6").
- Nominal pressure: PN16.
- Work temperature: -5 °C to 85 °C.
- Shell test: 1.5 PN.
- Seat test: 1.1 PN.
- Suitable medium: Water, ethylene glycol, etc.

Performance parameters

DN	Differential Pressure range KPa	Minimum flow m ³ /h	Maximum flow m ³ /h	Valve stroke mm	Actuator model
DN65	30 - 400	3.5	16	15	MD200Y-BA Actuator
DN80	30 - 400	4.0	27	15	MD200Y-BA Actuator
DN100	30 - 400	9.0	41	15	MD200Y-BA Actuator
DN125	30 - 400	15	50	30	MD300KY-BA Actuator
DN150	30 - 400	20	80	30	MD300KY-BA Actuator

TBFX Series Pressure Independent Control Valve dimensions valve + actuator (mm)

Order code	Size	DN	L	H1	H2	W	D	D1	D2	n-d	Weight (kg)
I0065CFDGMSSO	2.1/2"	65	290	399	177	206	185	145	118	4-19	27.8
I0080CFDGMSSO	3"	80	310	399	177	206	200	160	132	8-19	29.6
I0100CFDGMSSO	4"	100	350	403	177	206	220	180	156	8-19	33.5
I0125CFDGMSSO	5"	125	400	625	240	280	250	210	184	8-19	74.9
I0150CFDGMSSO	6"	150	480	635	260	300	285	240	211	8-23	84.9

Pressure Independent Control Valves

MD200Y-BA Actuator

Technical data:

- Voltage: 24 V AC.
- Power: 4.2 VA.
- Closing torque: 850 N.
- Maximum stroke: 20 mm.
- Input signal:
0(2) - 10 V or 0(4) - 20 mA.
- Feedback signal: 0 to 10V.
- Work temperature: 0 to 50 °C.
- Protection grade: IP54.

Features and benefits:

- Multiple input and output signal selection options, allowing fast simple system configuration.
- Self calibration, actuator accurately calibrates stroke length.
- Block protection prevents the valve from sticking if it has not moved for a long period of time.
- Safe mode: the actuator will power off automatically once the actuator has fully opened.

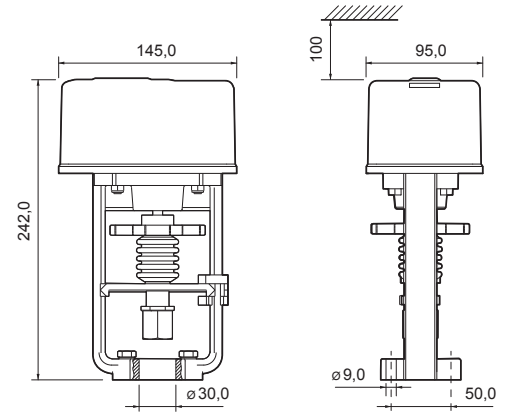

Function switch

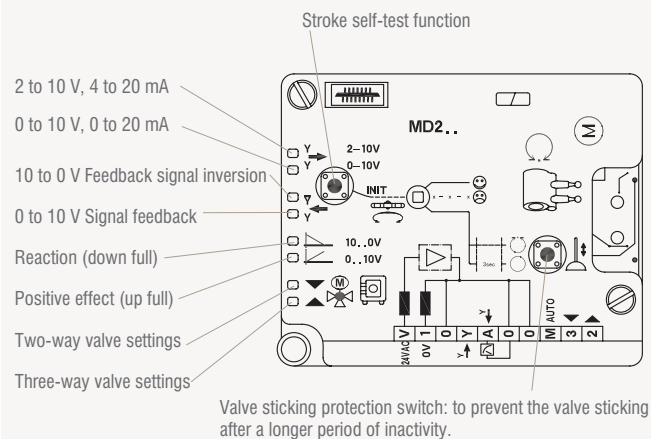

Safe mode

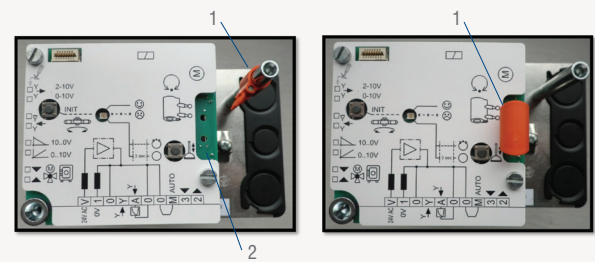

Knob (1) not inserted = manual mode

Knob (1) inserted = automatic mode

For safety reasons, the actuator automatically switches to manual mode when the cover is removed. To allow the commissioning technician to test functionality, the actuator can be switched to automatic mode using the included solenoid switch. Remove the actuator cover and then insert the knob (1) into the PCB (2).

Stroke indicator

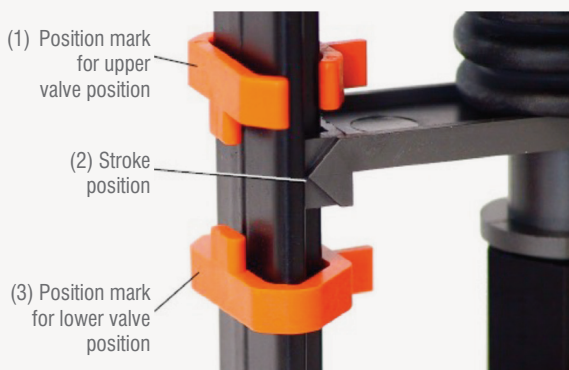

Operating instructions

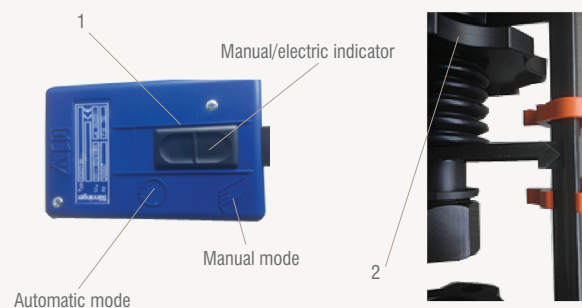

MD200Y-BA electric actuator can be operated in manual or automatic modes. When manual mode is activated, the extended slide indicator allows this status to be recognized even in poorly lit areas. In manual mode the actuator can be set to the desired valve position using the handwheel. After manual mode is switched off, the actuator resumes automatic positioning.

MD300KY-BA Actuator

Technical data:

- Voltage: 24 V AC.
- Power: 10.6 VA.
- Closing torque: 2200 N.
- Maximum stroke: 30 mm.
- Input signal: 0(2) - 10 V or 0(4) - 20 mA.
- Feedback signal: 0 - 10 V.
- Work temperature: 0 °C to 50 °C.
- Protection grade: IP54.

Features and benefits:

- Multiple input and output signal selection options, allowing fast simple system configuration.
- Self calibration, actuator accurately calibrates stroke length.
- Block protection prevents the valve from sticking if it has not moved for a long period of time.
- Safe mode: the actuator will power off automatically once the actuator has fully opened.

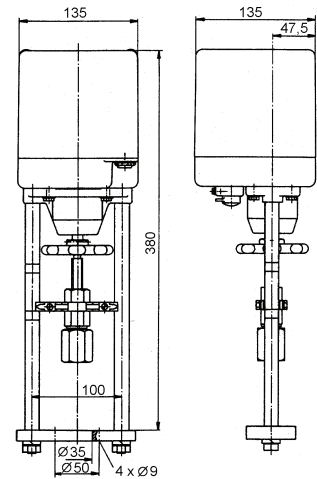

Installation space

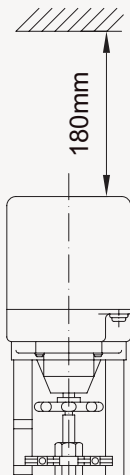

Stroke indicator

Position mark for the upper valve end position.

Position mark for the lower valve end position.

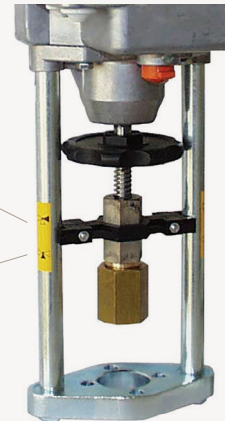

Operating instructions

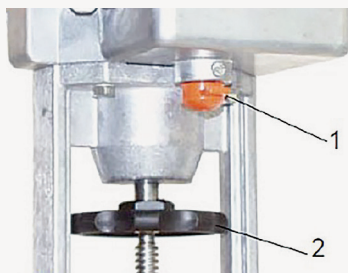

- Press the red button (1) and rotate button (quarter turn) to engage manual mode.
- The actuator position can then be adjusted manually by turning the handwheel (2).
- To return to automatic mode disengage the red button.





12.0 Plunger Valves

Conex Bänninger Plunger Valves are designed specifically for control tasks in water supply pipelines. Unlike gate valves and butterfly valves, which are mainly used as shut-off valves in pipeline networks, plunger valves are capable of providing control where volumetric flow rates need to be precisely apportioned or where water pressure has to be accurately controlled or reduced.

Product application:

FCEX Plunger Valves may be used to isolate a system or equipment for the purpose of:

- Drawing water: To adjust the pressure and flow rate in a gravity draw pipeline.
- Water storage: For fluid level control.
- Water transportation: Can be used to adjust flow rate and regulate pressure, thus avoiding pipeline bursts.
- Water treatment: Can be used to protect pumps during start-up and air capacity modulation in sewage treatment plants.
- Water supply: Can be used as a control valve for pressure flow modulation.
- Draining water: Can be used as a by-pass blow-down valve for dams and hydropower stations, etc.



FCEX Plunger Valves

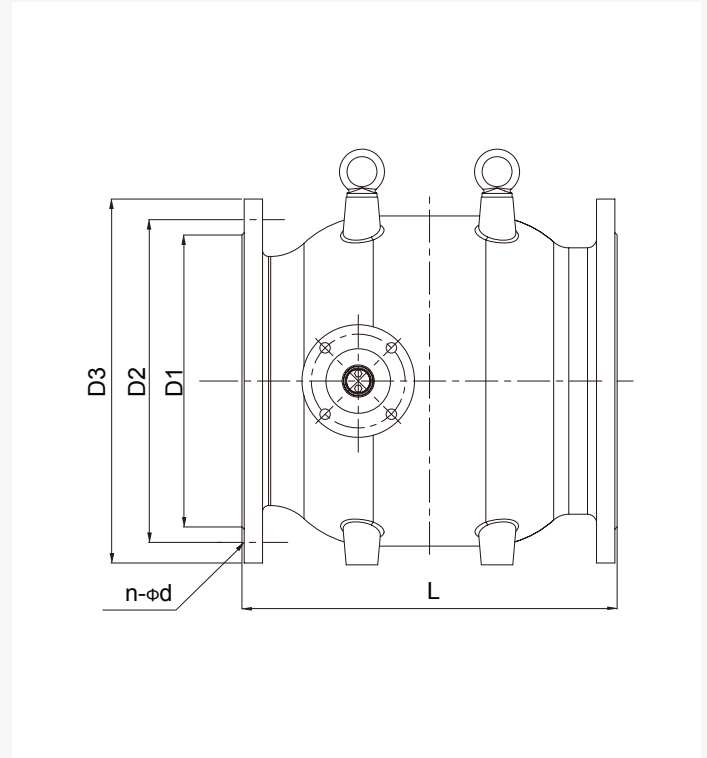

Material specification

FCEX Plunger Valves 10" to 64"

No	Component	Material
1	Body	Ductile iron
2	Crank	Ductile iron
3	Shaft	Stainless steel
4	Seat	304 stainless steel
5	O-ring	Rubber NBR
6	Sliding sleeve	304 stainless steel
7	Basic sleeve	304 stainless steel
8	Bearing	Bronze
9	Connecting rod	Stainless steel

Applicable standards:

- Flange dimension in accordance with EN 1092-2.
- Face to face dimension in accordance with EN 558-1 basic series 3.

Technical data:

- Size: DN 250 - DN 1600 (10" - 64").
- Maximum working pressure: 16 bar.
- Working temperature: 0 to 85 °C.
- Suitable medium: Air, water and other neutral liquids.

Features and benefits:

- Avoid cavitation corrosion and noise by controlling the water flow inside the valve channel to minimise low pressure zones.
- Counter balanced structure, reduces the operating torque under high pressure and high flow rates.
- Cage, disc designed for linear regulation. 100% linear modulation of the flow rate facilitates matching with a variety of applications.
- Metal to metal sealing, extremely smooth surface finish $\leq 0.8\mu\text{m}$ ensures zero leakage.
- Inner parts manufactured from long life corrosion resistant stainless steel.
- Self-lubricating bronze bushing, reduces friction, and lowers operating torque.
- Valve functions: Flow rate regulation, pressure modulation, fluid level control, and draining.
- Methods of operation: Gearbox, pneumatic actuator and motorised actuator enabling drive customisation in-line with applications requirements.
- Low actuating torque due to pressure balanced valve piston.
- Rotationally symmetrical flow guidance.
- Annular flow cross section in each position.
- Axial movement of the plunger by means of crank gear mechanism.
- Self-locking worm gear unit with position indicator.
- Sealing ring located in the no-flow zone for durability.
- Wear-resistant, corrosion-resistant, infiltration-proof, micro-finished stainless steel piston guides in the valve body.

FCEX Plunger Valve

Type	Size	DN	D1 mm	D2 mm	D3 mm	L mm	n-φd
FCEX-0250C	10"	250	319	355	405	500	12-28
FCEX-0300C	12"	300	370	410	460	500	12-28
FCEX-0350C	14"	350	429	470	520	700	16-28
FCEX-0400C	16"	400	480	525	580	800	16-31
FCEX-0500C	20"	500	609	650	715	1000	20-34
FCEX-0600C	24"	600	720	770	840	1200	20-37
FCEX-0700C	28"	700	794	840	910	1400	24-37
FCEX-0800C	32"	800	901	950	1025	1600	24-40
FCEX-0900C	36"	900	1001	1050	1125	1800	28-40
FCEX-1000C	40"	1000	1112	1170	1255	2000	28-43
FCEX-1200C	48"	1200	1328	1390	1485	2400	32-49
FCEX-1400C	56"	1400	1530	1590	1685	2800	36-49
FCEX-1600C	64"	1600	1750	1820	1930	3200	40-56

Note: Order codes available on request.

13.0 Product Guarantee

When professionally installed, used and maintained in accordance with the installation and maintenance instructions detailed in the appropriate technical manual available on the Conex Bänninger website (www.conexbanninger.com), Conex Universal Ltd. guarantees that the product families listed below and supplied by Conex Universal Ltd. will be free of material defects resulting from errors in manufacture, for the applicable number of years for the relevant product family set out in the table below from the date of first purchase by an end user. This Guarantee is limited to the repair or replacement of defective product(s) (at the sole discretion of Conex Universal Ltd.). At the request of Conex Universal Ltd. the allegedly defective product(s) must be returned to the address below* and Conex Universal Ltd. reserves the right to inspect and test the alleged defects. This guarantee provided by Conex Universal Ltd. does not affect your statutory rights.

Product families covered by this Guarantee

Product family – fittings and valves	Guarantee period (years)
Industrial Valves	5
Specification Valves	5
Ball Valves	5

* The address for returns is:

Customer Services at Conex Universal Limited, Global House, 95 Vantage Point, The Pensnett Estate, Kingswinford, West Midlands DY6 7FT, UNITED KINGDOM

The guarantee set out above is given by Conex Universal Ltd. and subject to the following conditions:

- A. Any alleged defects must be reported to Conex Universal Ltd. within one month of the first occurrence of any such alleged defect, clearly setting out the nature of the claim and the circumstances surrounding it.
- B. Conex Universal Ltd. shall be under no liability in respect of any defect in any product arising from:
- defective installation,
 - fair wear and tear,
 - wilful damage,
 - negligence of any party other than Conex Universal Ltd.,
 - abnormal working or environmental conditions,
 - failure to follow the instructions of Conex Universal Ltd.,
 - misuse (which includes any use of the product(s) concerned for a purpose or in a situation / environment or for an application other than that for which it was designed), or
 - alteration or repair of any product without the prior approval of Conex Universal Ltd.
- C. At the request of Conex Universal Ltd. the person claiming under this guarantee must deliver to Conex Universal Ltd. written evidence of the date of first purchase by an end user of the product(s) concerned.

14.0 Notes

Conex | Bänninger

Conex | Bänninger
>B< Press

Conex | Bänninger
>B< Press Gas

Conex | Bänninger
>B< Press Solar

Conex | Bänninger
>B< Press XL

Conex | Bänninger
>B< Press Carbon

Conex | Bänninger
>B< Press Inox

Conex | Bänninger
>B< MaxiPro

Conex | Bänninger
>B< ACR

K65[®]

Conex | Bänninger
>B< Push

Conex | Bänninger
>B< Flex

Conex | Bänninger
>B< Oyster

Conex | Bänninger
>B< Sonic

Conex | Bänninger
Triflow Solder Ring

Conex | Bänninger
Delcop End Feed

Conex | Bänninger
Delbraze

Conex | Bänninger
Medical Gas

Conex | Bänninger
Valves

Conex | Bänninger
Conex Compression

Conex | Bänninger
Series 3000

Conex | Bänninger
Series 4000

Conex | Bänninger
Series 5000

Conex | Bänninger
Series 8000

Conex | Bänninger
OEM

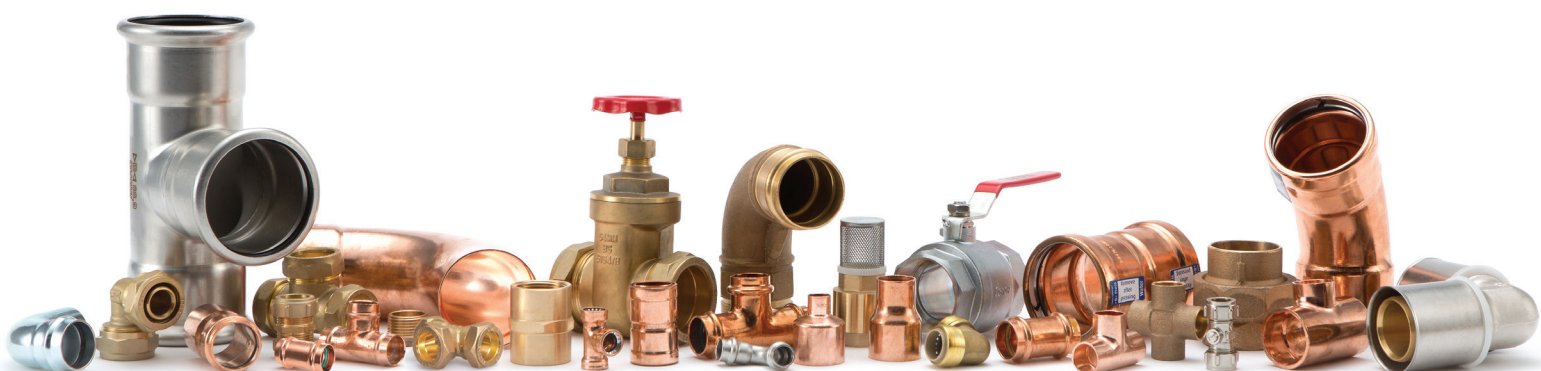

United Kingdom
Conex Universal Limited

Germany
IBP GmbH

Spain
IBP Atcosa SL

France
Conex Bänninger SRL

Italy
IBP Bänninger Italia srl

Poland Sales, Marketing and Logistics
IBP Instalfittings Sp z.o.o.

USA
IBP Group LLC

China
IBP China

Conex Universal Limited: One JLT Tower, Level 5, Office 12, Jumeirah Lake Towers, Dubai, UAE
Tel: +971 (0) 4 434 0082 | Email: gulf@ibpgroup.com | Website: www.conexbanninger.com

The content of this publication is for general information only. It is the user's responsibility to determine suitability of any product for the purpose intended and reference should be made to our Technical Department if clarification is required. In the interests of technical development we reserve the right to change specification, design and materials without notice.

Conex Bänninger products are approved by numerous Standards Authorities and Certification Bodies. For more details on this product range, please email our technical team: technical@ibpgroup.com. This is a representation of the full range from Conex Universal Ltd. IBP trademarks are registered in numerous countries.